

# TECHNICAL MANUAL



## ACVC9/AMVC95 GCVC9/GMVC95

### 90%-95% Gas Furnace Units

- Refer to Service Manual RS6200004 for installation, operation, and troubleshooting information.
- All safety information must be followed as provided in the Service Manual.
- Refer to the appropriate Parts Catalog for part number information.
- Models listed on page 3.

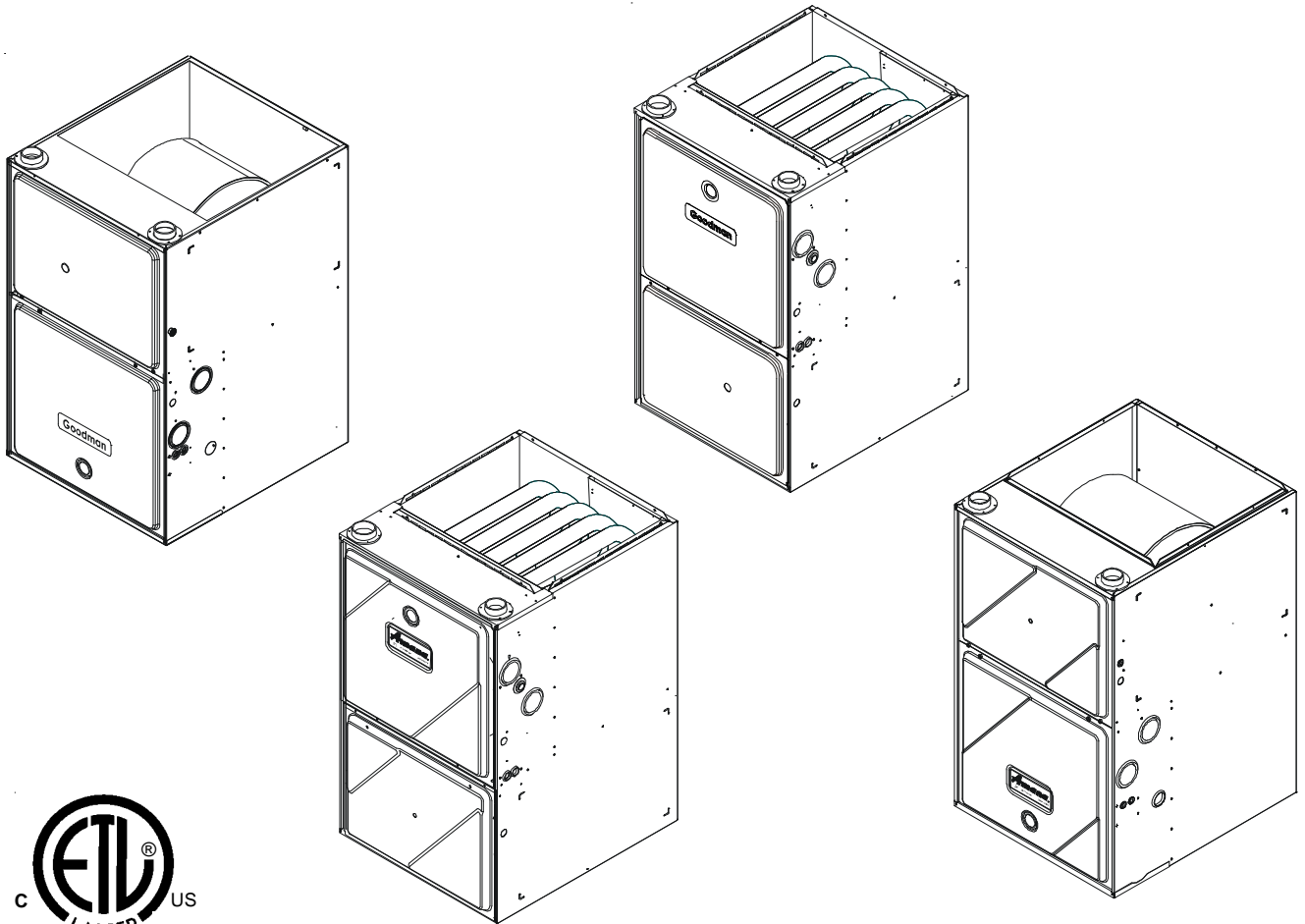



This manual is to be used by qualified, professionally trained HVAC technicians only. Goodman does not assume any responsibility for property damage or personal injury due to improper service procedures performed by an unqualified person.

RT6612021 Rev.3  
August 2010

# PRODUCT IDENTIFICATION

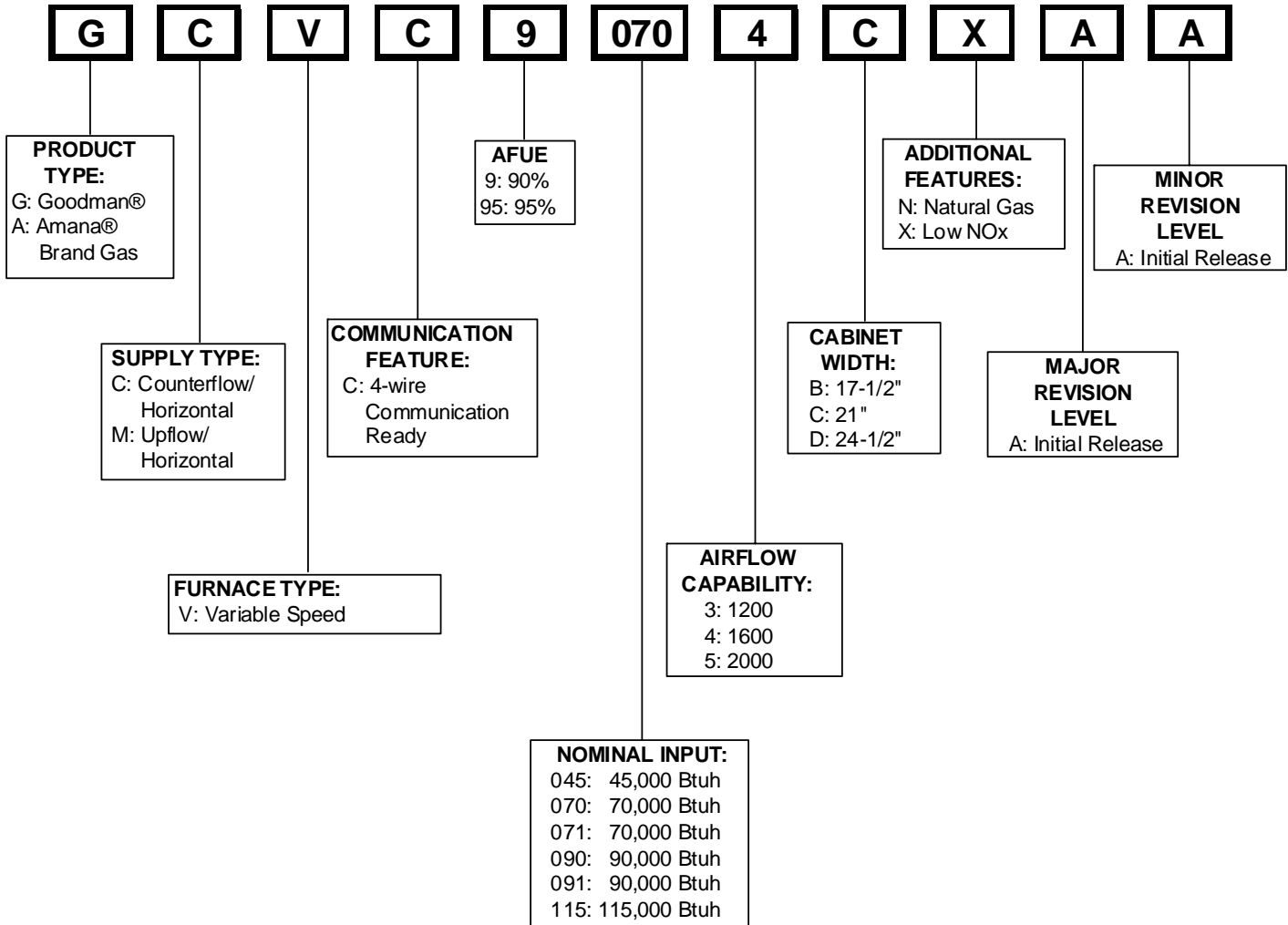
The model and manufacturing number are used for positive identification of component parts used in manufacturing. Please use these numbers when requesting service or parts information.



 **WARNING** **HIGH VOLTAGE!** Disconnect ALL power before servicing or installing this unit. Multiple power sources may be present. Failure to do so may cause property damage, personal injury or death. 

 **WARNING** Goodman will not be responsible for any injury or property damage arising from improper service or service procedures. If you install or perform service on this unit, you assume responsibility for any personal injury or property damage which may result. Many jurisdictions require a license to install or service heating and air conditioning equipment.

 **WARNING** Installation and repair of this unit should be performed ONLY by individuals meeting the requirements of an "entry level technician", at a minimum, as specified by the Air-Conditioning, Heating, and Refrigeration Institute (AHRI). Attempting to install or repair this unit without such background may result in product damage, personal injury or death.

# PRODUCT IDENTIFICATION

The model and manufacturing number are used for positive identification of component parts used in manufacturing. Please use these numbers when requesting service or parts information.

GMVC950453BXAA  
GMVC950704CXAA  
GMVC950905CXAA  
GMVC950905DXAA  
GMVC951155DXAA

AMVC950453BXAA  
AMVC950704CXAA  
AMVC950905CXAA  
AMVC950905DXAA  
AMVC951155DXAA

GCVC90704CXAA  
GCVC90905DXAA  
GCVC91155DXAA

ACVC90704CXAA  
ACVC90905DXAA

GMVC950453BXAB  
GMVC950704CXAB  
GMVC950905DXAB  
GMVC951155DXAB

AMVC950453BXAB  
AMVC950704CXAB  
AMVC950905DXAB  
AMVC951155DXAB

GCVC90704CXAB  
GCVC90905DXAB  
GCVC91155DXAB

ACVC90704CXAB  
ACVC90905DXAB

GCVC950714CXAA  
GCVC950915DXAA

ACVC950714CXAA  
ACVC950915DXAA



The United States Environmental Protection Agency ("EPA") has issued various regulations regarding the introduction and disposal of refrigerants introduced into this unit. Failure to follow these regulations may harm the environment and can lead to the imposition of substantial fines. These regulations may vary by jurisdiction. Should questions arise, contact your local EPA office.



Do not connect or use any device that is not design certified by Goodman for use with this unit. Serious property damage, personal injury, reduced unit performance and/or hazardous conditions may result from the use of such non-approved devices.



To prevent the risk of property damage, personal injury, or death, do not store combustible materials or use gasoline or other flammable liquids or vapors in the vicinity of this appliance.

# PRODUCT DESIGN

## General Operation

Models covered by this manual come with a new 4-wire communicating PCB. When paired with a compatible communicating indoor unit and a CTK01AA communicating thermostat, these models can support 4-wire communication protocol and provide more troubleshooting information. These models are also backward compatible with the legacy thermostat wiring.

The GCVC9, GCVC95, GMVC95, AMVC95, ACVC9 and ACVC95 furnaces are equipped with an electronic ignition device to light the burners and an induced draft blower to exhaust combustion products.

An interlock switch prevents furnace operation if the blower door is not in place. Keep the blower access doors in place except for inspection and maintenance.

These furnaces are also equipped with a self-diagnosing electronic control module. In the event a furnace component is not operating properly, the control module's dual 7-segment LED's will display an alpha-numeric code, depending upon the problem encountered. These LED's may be viewed through the observation window in the blower access door. Refer to the *Troubleshooting Chart* for further explanation of the LED codes and *Abnormal Operation - Integrated Ignition Control* section in the Service Instructions for an explanation of the possible problem.

The rated heating capacity of the furnace should be greater than or equal to the total heat loss of the area to be heated. The total heat loss should be calculated by an approved method or in accordance with "ASHRAE Guide" or "Manual J-Load Calculations" published by the Air Conditioning Contractors of America.

\*Obtain from: American National Standards Institute 1430 Broadway New York, NY 10018

## Location Considerations

- The furnace should be as centralized as is practical with respect to the air distribution system.
- Do not install the furnace directly on carpeting, tile, or combustible material other than wood flooring.
- When suspending the furnace from rafters or joists, use 3/8" threaded rod and 2" x 2" x 1/8" angle as shown in the Installation and Service Instructions. The length of the rod will depend on the application and clearance necessary.
- When installed in a residential garage, the furnace must be positioned so the burners and ignition source are located not less than 18 inches (457 mm) above the floor and protected from physical damage by vehicles.

## Notes:

1. Installer must supply one or two PVC pipes: one for combustion air (optional) and one for the flue outlet (required). Vent pipe must be either 2" or 3" in diameter, depending upon furnace input, number of elbows, length of run and

installation (1 or 2 pipes). The optional Combustion Air Pipe is dependent on installation/code requirements and must be 2" or 3" diameter PVC.

2. Line voltage wiring can enter through the right or left side of the furnace. Low voltage wiring can enter through the right or left side of furnace.
3. Conversion kits for propane gas and high altitude natural and propane gas operation are available. See High Altitude Derate chart for details.
4. Installer must supply the following gas line fittings, depending on which entrance is used:

**Left** -- Two 90° Elbows, one close nipple, straight pipe

**Right** -- Straight pipe to reach gas valve.

## Accessibility Clearances (Minimum)

*MVC95* MINIMUM CLEARANCES TO COMBUSTIBLE MATERIALS (INCHES)						
POSITION*	FRONT	SIDES	REAR	TOP	FLUE	FLOOR
Upflow	3	0	0	1	0	C
Horizontal	Alcove	6	0	4	0	C

\*= All positioning is determined as installed unit is viewed from the front.

C= If placed on combustible floor, floor MUST be wood only.

NC= For installation on non-combustible floors only. A combustible subbase must be used for installations on combustible flooring.

*CVC9 MINIMUM CLEARANCES TO COMBUSTIBLE MATERIALS (INCHES)						
POSITION*	FRONT	SIDES	REAR	TOP	FLUE	FLOOR
Upflow	1	0	0	1	0	NC
Horizontal	Alcove	6	0	4	0	C

\*= All positioning is determined as installed unit is viewed from the front.

C= If placed on combustible floor, floor MUST be wood only.

NC= For installation on non-combustible floors only. A combustible subbase must be used for installations on combustible flooring.

## Alcove Illustration

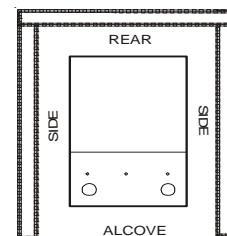

24" at front is required for servicing or cleaning.

Note: In all cases accessibility clearance shall take precedence over clearances from the enclosure where accessibility clearances are greater. All dimensions are given in inches.

## High Altitude Derate

When this furnace is installed at high altitude, the appropriate High Altitude orifice kit must be installed. This is re-

# PRODUCT DESIGN

quired due to the natural reduction in the density of both the gas fuel and combustion air as altitude increases. The kit will provide the proper design certified input rate within the specified altitude range.

High altitude kits are purchased according to the installation altitude and usage of either natural or propane gas. Refer to the chart above for a tabular listing of appropriate altitude ranges and corresponding manufacturer's high altitude Natural Gas and Propane Gas kits. For a tabular listing of appropriate altitude ranges and corresponding manufacturer's High Altitude Pressure Switch kits, refer to either the *Pressure Switch Trip Points & Usage Chart* in this manual or the *Accessory Charts* in Service Instructions.

## Single Stage Thermostat

A single-stage thermostat with only one heating stage may be used to control this furnace. The application of a single-stage thermostat does not offer "true" thermostat-driven two-stage operation, but provides a *timed* transition from low to high fire. The furnace will run on low stage for a fixed period

of time before stepping up to high stage to satisfy the thermostat's call for heat. The delay period prior to stepping up can be set at either a fixed 5 minute time delay or a load based variable time between 1 and 12 minutes (AUTO mode). If the AUTOMode is selected, the control averages the cycle times of the previous three cycles and uses the average to determine the time to transition from low stage to high stage.

To use a single-stage thermostat, turn off power to the furnace, move the thermostat selection DIP switch to the OFF position. Set the desired transition time by setting the transition delay DIP switch to the desired ON/OFF position. Turn power back on. Refer to the following figure.

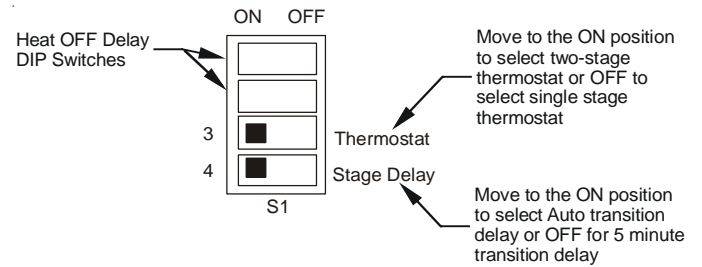

Furnace	"STANDARD" and "HIGH ALTITUDE" KITS								
	0 - 7,000 Feet (Standard Altitude)			7,001 - 9,000 Feet			9,001 - 11,000 Feet		
	Gas Orifices		ID Blwr Pressure Switch	Gas Orifices		ID Blwr Pressure Switch	Gas Orifices		ID Blwr Pressure Switch
Natural	Propane	Natural		Propane	Natural		Propane		
GMVC950453BX* GMVC950704CX* AMVC950453BX* AMVC950704CX*	No Change	LPM-05 <sup>*(1)</sup> LPM-06 <sup>*(2)</sup> #55 Orifice	No Change	HANG13 #44 Orifice	HALP11 #56 Orifice	HAPS28	HANG14 #45 Orifice	HALP11 #56 Orifice	HAPS28
GMVC950905CX* AMVC950905CX*	No Change	LPM-05 <sup>*(1)</sup> LPM-06 <sup>*(2)</sup> #55 Orifice	No Change	N/A	N/A	N/A	N/A	N/A	N/A
GMVC950905DX* GMVC951155DX* AMVC950905DX* AMVC951155DX*	No Change	LPM-05 <sup>*(1)</sup> LPM-06 <sup>*(2)</sup> #55 Orifice	No Change	HANG13 #44 Orifice	HALP11 #56 Orifice	HAPS29	HANG14 #45 Orifice	HALP11 #56 Orifice	HAPS29
GCVC90704CX* GCVC90905DX* GCVC91155DX* ACVC90704CX* ACVC90905DX*	No Change	LPM-05 <sup>*(1)</sup> LPM-06 <sup>*(2)</sup> #55 Orifice	No Change	HANG13 #44 Orifice	HALP11 #56 Orifice	HAPS29	HANG14 #45 Orifice	HALP11 #56 Orifice	HAPS31
GCVC950714CX* GCVC950915DX* ACVC950714CX* ACVC950915DX*	No Change	LPM-05 <sup>*(1)</sup> LPM-06 <sup>*(2)</sup> #55 Orifice	No Change	N/A	N/A	N/A	N/A	N/A	N/A

<sup>1</sup> LPM-05\* supports White-Rodgers 2-stage valves only

<sup>2</sup> LPM-06\* supports Honeywell and White-Rodgers 2-stage valves

# COMPONENT IDENTIFICATION

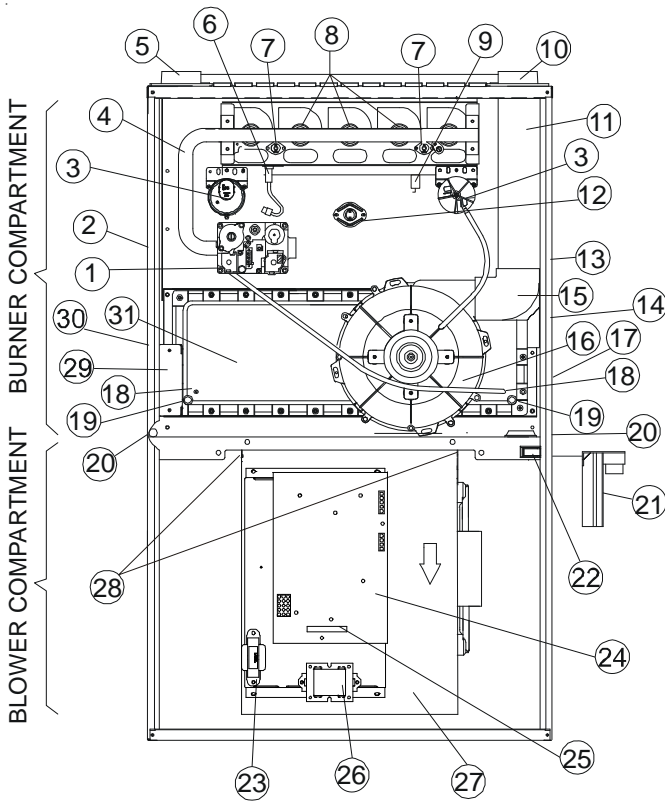

Upflow/Horizontal

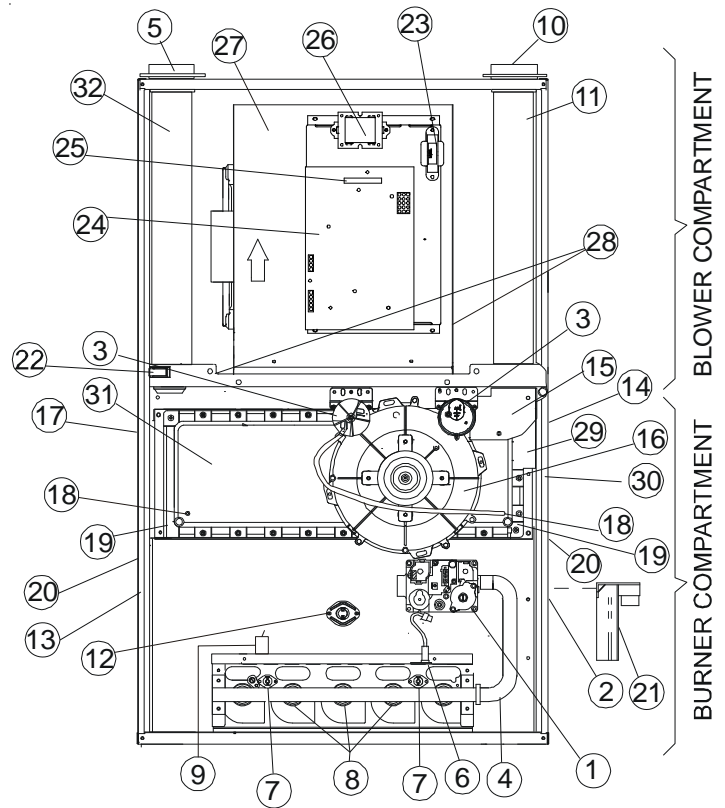

Counterflow/Horizontal

- |   |  |
|---|--|
| 1 Two-Stage Gas Valve                       | 18 Coil Front Cover Pressure Tap   |
| 2 Gas Line Entrance (Alternate)             | 19 Coil Front Cover Drain Port   |
| 3 Pressure Switch(es)                       | 20 Drain Line Penetrations   |
| 4 Gas Manifold                              | 21 Drain Trap  |
| 5 Combustion Air Intake Connection          | 22 Blower Door Interlock Switch  |
| 6 Hot Surface Igniter                       | 23 Inductor (Not All Models)   |
| 7 Rollout Limit                             | 24 Two-Stage Integrated Control Module<br>(with fuse and diagnostic LED) |
| 8 Burners                                   | 25 24 Volt Thermostat Connections  |
| 9 Flame Sensor                              | 26 Transformer (40 VA)   |
| 10 Flue Pipe Connection                     | 27 ECM Variable Speed Circulator Blower                                  |
| 11 Flue Pipe                                | 28 Auxiliary Limit   |
| 12 Primary Limit                            | 29 Junction Box  |
| 13 Gas Line Entrance                        | 30 Electrical Connection Inlets  |
| 14 Flue Pipe Connection (Alternate)         | 31 Coil Front Cover  |
| 15 Rubber Elbow                             | 32 Combustion Air Inlet Pipe (*CVC9/95 only)                             |
| 16 Two-Speed Induced Draft Blower           |  |
| 17 Electrical Connection Inlets (Alternate) |  |

# PRODUCT DIMENSIONS

# GMVC95/AMVC95 \_\_\_X\*

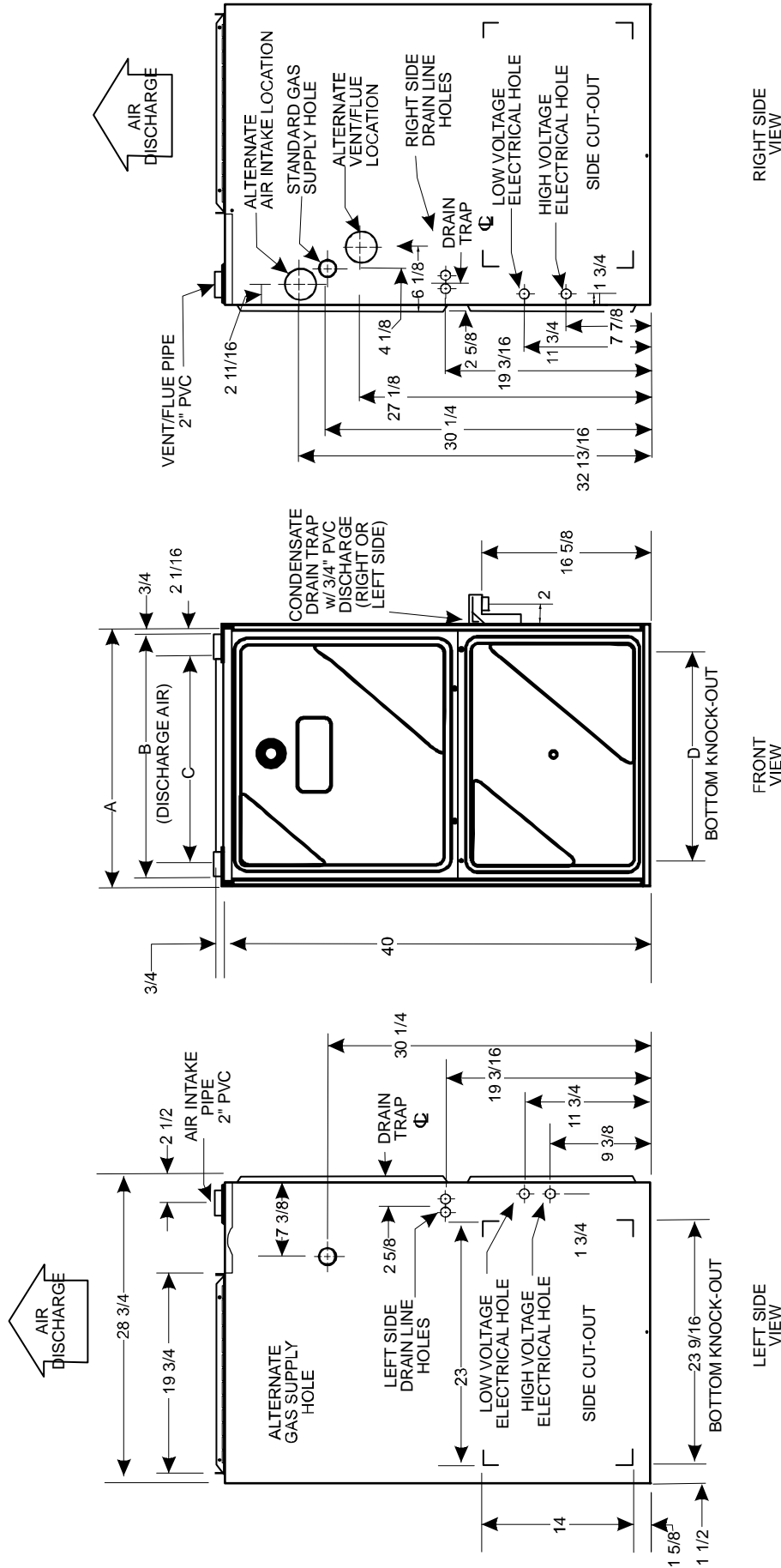

CABINET SIZE	UNITS	A	B	C	D
SMALL	0453BX*	17 1/2	15	12 3/8	12 5/8
MEDIUM	0704CX* 0905CX*	21	19	16 3/8	14 5/8
LARGE	0905DX* 1155DX*	24 1/2	23	20 3/8	18 5/8

All dimensions are in inches.

\* NOTE: Airflow area will be reduced by approximately 18% if duct flanges are not unfolded. This could cause performance issues and noise issues.

# PRODUCT DIMENSIONS

# GVCV9/ACVC9          X\*

FRONTVIEW

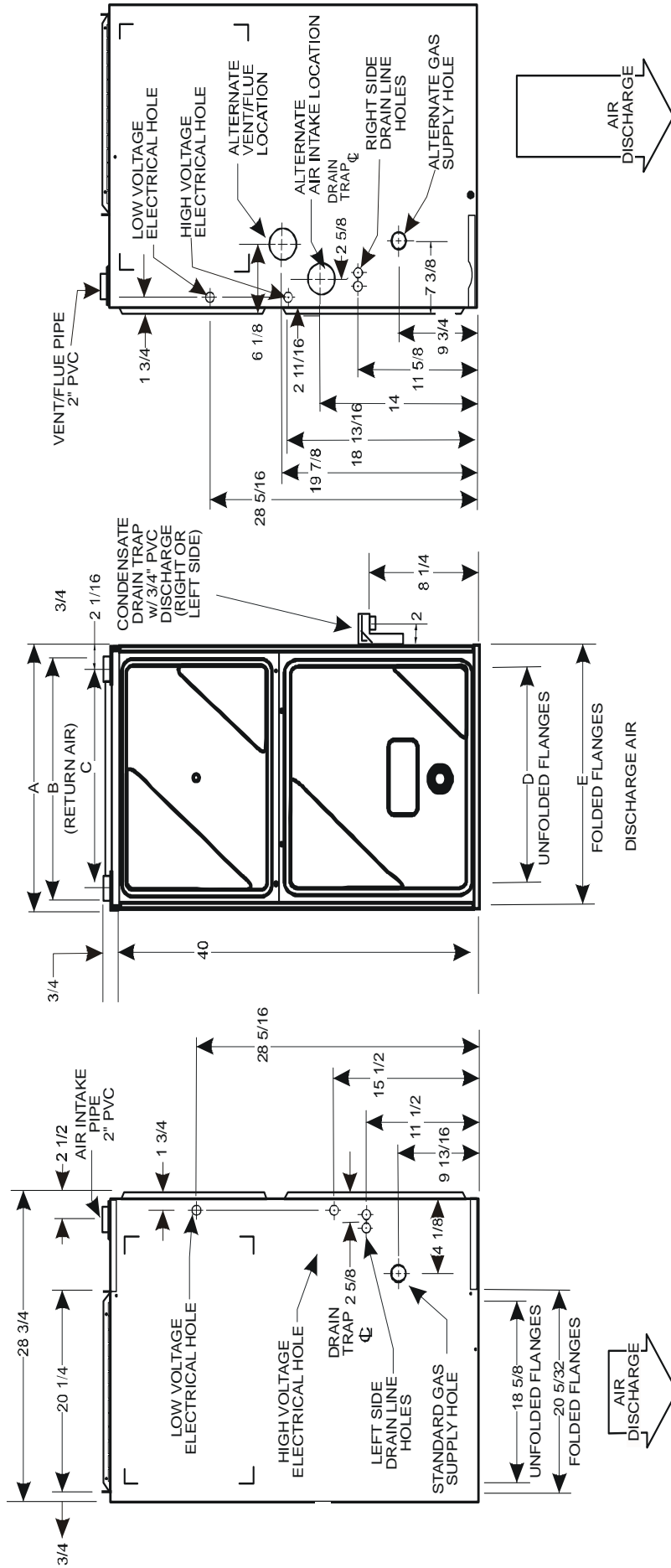

CABINET SIZE	UNITS	A	B	C	D	E
MEDIUM	0704CX* 0714CX*	21	19	16 3/8	14 5/8	17 1/2
LARGE	0905DX* 0915DX* 1155DX*	24 1/2	23	20 3/8	18 5/8	20 7/8

All dimensions are in inches.

**NOTE:** Airflow area will be reduced by approximately 18% if duct flanges are not unfolded. This could cause performance issues and noise issues.



# PRODUCT DESIGN

PRESSURE SWITCH TRIP POINTS AND USAGE CHART								
MODEL	NEGATIVE PRESSURE ID BLOWER WITH FLUE NOT FIRING TYPICAL SEA LEVEL DATA <sup>(1)</sup>		NEGATIVE PRESSURE ID BLOWER WITH FLUE FIRING TYPICAL SEA LEVEL DATA <sup>(2)</sup>		NEGATIVE PRESSURE COIL COVER WITH FLUE NOT FIRING TYPICAL SEA LEVEL DATA <sup>(1)</sup>		NEGATIVE PRESSURE COIL COVER WITH FLUE FIRING TYPICAL SEA LEVEL DATA <sup>(2)</sup>	
	LOW FIRE	HIGH FIRE	LOW FIRE	HIGH FIRE	LOW FIRE	HIGH FIRE	LOW FIRE	HIGH FIRE
GMVC950453BX* GMVC950704CX* AMVC950453BX* AMVC950704CX*	-0.45	-0.90	-0.50	-0.95	-0.25	-0.25	-0.25	-0.25
GMVC950905CX* AMVC950905CX*	-0.75	-1.85	-0.60	-1.70	-0.10	-0.10	-0.10	-0.10
GMVC950905DX* GMVC951155DX* AMVC950905DX* AMVC951155DX*	-0.65	-1.20	-0.70	-1.25	-0.25	-0.25	-0.25	-0.25
GCVC90704CX* ACVC90704CX*	-0.35	-0.70	-0.20	-0.55	-0.52	-0.52	-0.37	-0.37
GCVC950714CX* ACVC950714CX*	-0.95	-1.75	-1.00	-1.80	-0.10	-0.10	-0.10	-0.10
GCVC90905DX* ACVC90905DX*	-0.35	-0.70	-0.20	-0.55	-0.52	-0.52	-0.37	-0.37
GCVC950915DX* ACVC950915DX*	-0.95	-1.75	-1.00	-1.80	-0.10	-0.10	-0.10	-0.10
GCVC91155DX*	-0.35	-0.70	-0.20	-0.55	-0.52	-0.52	-0.37	-0.37

(1) Data given is least negative pressure required for pressure switch to close.

(2) Data given is least negative pressure required for pressure switch to remain closed.

Note: The typical sea level negative pressure data represents the minimum pressures expected. Shorter length of flue pipe or single pipe systems compared to dual pipe systems should show higher (greater negative) pressures.

# PRODUCT DESIGN

PRESSURE SWITCH TRIP POINTS AND USAGE CHART											
0 to 7,000 ft.											
MODEL	TRIP POINT COIL COVER PRESSURE SWITCH		COIL COVER PRESSURE SWITCH PART #	TRIP POINT ID BLOWER PRESSURE SWITCH		ID BLOWER PRESSURE SWITCH PART #	TRIP POINT COIL COVER PRESSURE SWITCH		TRIP POINT ID BLOWER PRESSURE SWITCH		HIGH ALTITUDE KIT
	LOW FIRE	HIGH FIRE		LOW FIRE	HIGH FIRE		LOW FIRE	HIGH FIRE	LOW FIRE	HIGH FIRE	
	7,001 ft. to 11,000 ft.										
GMVC950453BX*	-0.10	-0.10	20197308	-0.30	-0.75	11177113	-0.10	-0.10	-0.22	-0.55	HAPS28 11177115
GMVC950704CX*											
AMVC950453BX*											
AMVC950704CX*											
GMVC950905CX*	-0.10	-0.10	0130F00070	-0.60	-1.70	0130F00111	N/A	N/A	N/A	N/A	N/A
AMVC950905CX*											
GMVC950905DX*											
GMVC951155DX*	-0.10	-0.10	20197308	-0.50	-1.10	11177114	-0.10	-0.10	-0.38	-0.82	HAPS29 11177116
AMVC950905DX*											
AMVC951155DX*											
GCVC90704CX*	-0.37	-0.37	20197313	-0.20	-0.55	11177118	-0.37	-0.37	-0.15	-0.30	HAPS31
ACVC90704CX*											
GCVC950714CX*	-0.10	-0.10	0130F00070	-0.80	-1.60	0130F00100	N/A	N/A	N/A	N/A	N/A
ACVC950714CX*											
GCVC90905DX*	-0.37	-0.37	20197313	-0.20	-0.55	11177118	-0.37	-0.37	-0.15	-0.30	HAPS31
ACVC90905DX*											
GCVC950915DX*	-0.10	-0.10	0130F00070	-0.80	-1.60	0130F00100	N/A	N/A	N/A	N/A	N/A
ACVC950915DX*											
GCVC91155DX*	-0.37	-0.37	20197313	-0.20	-0.55	11177118	-0.37	-0.37	-0.15	-0.30	HAPS31

**Note:** All installations above 7,000 ft. require a pressure switch change. For installations in Canada the \*MVC95 & \*CVC9/95 furnaces are certified only to 4500 ft.

**Note:** Replacement pressure switch number is listed below high altitude kit number.

**Note:** All negative pressure readings are in inches of water column (" w.c.).

# PRODUCT DESIGN

PRIMARY LIMIT						
Part Number	20162903	20162904	20162905	20162907	20162908	0130F00105
Open Setting (°F)	160	150	145	155	170	130
GMVC950453BX* AMVC950453BX*	---	---	1	---	---	---
GMVC950704CX* AMVC950704CX*	---	---	---	1	---	---
GMVC950905CX* AMVC950905CX*	---	---	---	---	---	1
GMVC950905DX* AMVC950905DX*	---	---	1	---	---	---
GMVC951155DX* AMVC951155DX*	---	1	---	---	---	---
GCVC90704CX* ACVC90704CX*	1	---	---	---	---	---
GCVC950714CX* ACVC950714CX*	---	1	---	---	---	---
GCVC90905DX* ACVC90905DX*	---	---	---	---	1	---
GCVC950915DX* ACVC950915DX*	---	---	---	---	---	1
GCVC91155DX*	---	---	1	---	---	---

ROLLOUT LIMIT SWITCHES						
Part Number	10123512	10123517	10123518	10123533	10123534	10123537
Open Setting (°F)	325	210	170	200	220	190
GMVC950453BX* AMVC950453BX*	---	---	1	---	---	---
GMVC950704CX* AMVC950704CX*	---	---	---	2	---	---
GMVC950905CX* AMVC950905CX*	---	---	---	2	---	---
GMVC950905DX* AMVC950905DX*	---	---	---	---	---	2
GMVC951155DX* AMVC951155DX*	---	---	---	2	---	---

GCVC90704CX* ACVC90704CX*	---	---	---	---	2	---
GCVC950714CX* ACVC950714CX*	---	2	---	---	---	---
GCVC90905DX* ACVC90905DX*	---	2	---	---	---	---
GCVC950915DX* ACVC950915DX*	---	2	---	---	---	---
GCVC91155DX*	---	2	---	---	---	---

# PRODUCT DESIGN

AUXILIARY LIMIT SWITCHES						
Part Number	10123534	10123535	10123537	10123536	10123533	0130F00038
Open Setting (°F)	220	150	190	180	200	120
GMVC950453BX* AMVC950453BX*	--	2	---	---	---	---
GMVC950704CX* AMVC950704CX*	---	---	2	---	---	---
GMVC950905CX* AMVC950905CX*	---	---	---	---	---	2
GMVC950905DX* AMVC950905DX*	---	---	---	2	---	---
GMVC951155DX* AMVC951155DX*	---	---	---	---	2	---

GCVC90704CX* ACVC90704CX*	2	---	---	---	---	---
GCVC950714CX* ACVC950714CX*	---	---	---	---	---	2
GCVC90905DX* ACVC90905DX*	---	---	---	2	---	---
GCVC950915DX* ACVC950915DX*	---	---	---	---	---	2
GCVC911555DX*	---	---	---	2	---	---

# PRODUCT DESIGN

## Coil Matches:

A large array of Amana® brand coils are available for use with the GCVC9 and ACVC9 furnaces, in either counterflow or horizontal applications & with GMVC95 and AMVC95 furnaces, in either upflow or horizontal applications. These coils are available in both cased and uncased models (with the option of a field installed TXV expansion device). These 92%+ and 95%+ furnaces match up with the existing Amana® brand coils as shown in the chart below.

## Coil Matches (for Goodman® and Amana® Brand units using R22 and R-410A):

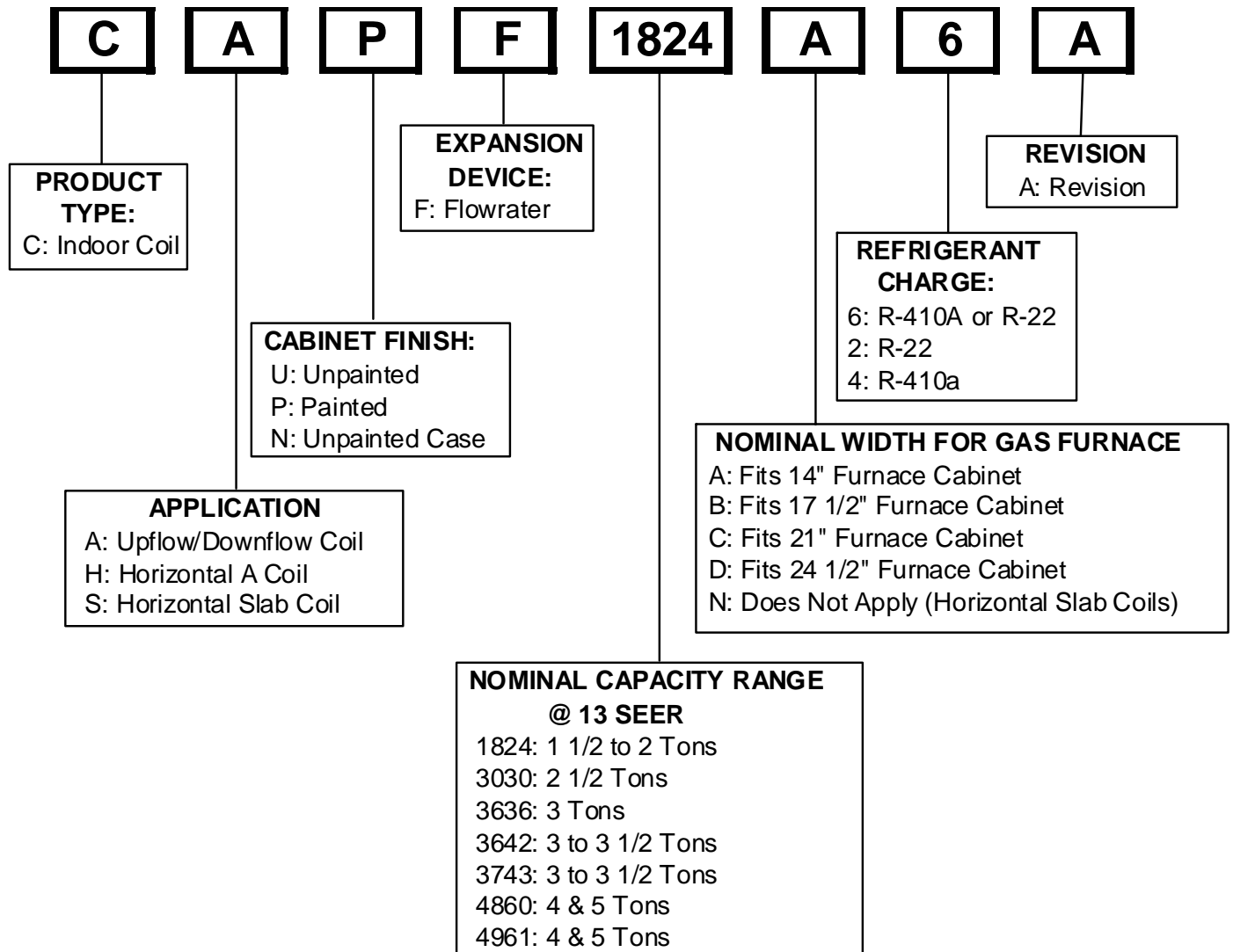

- All CAPF coils in B, C, & D widths have insulated blank off plates for use with one size smaller furnaces.
- All CAPF coils have a CAUF equivalent.
- All CHPF coils in B, C & D heights have an insulated Z bracket for use with one size smaller furnace.
- All proper coil combinations are subject to being ARI rated with a matched outdoor unit.

# PRODUCT DESIGN

## Thermostats:

ComfortNet™ CTK01A\* Thermostat Kit

## Filters:

Filters are required with this furnace and must be provided by the installer. The filters used must comply with UL900 or CAN/ULCS111 standards. Installing this furnace without filters will void the unit warranty

### Upflow Filters

Return air filters may be installed at the furnace side and/or bottom return openings. The furnace bottom return opening and side openings will accommodate the following filter sizes depending on cabinet size:

Side Return Opening(s)		
Cabinet Width (in.)	Nominal Filter Size (in.)	Approx. Flow Area (in <sup>2</sup> )
All	16 x 25 x 1	400

Bottom Return Opening		
Cabinet Width (in.)	Nominal Filter Size (in.)	Approx. Flow Area (in <sup>2</sup> )
17-1/2	14 x 25 x 1	350
21	16 x 25 x 1	400
24-1/2	20 x 25 x 1	500

Refer to Minimum Filter Area tables to determine filter area requirement. **NOTE:** Filters can also be installed elsewhere in the duct system such as a central return.

		UPFLOW COOLING AIRFLOW REQUIREMENT (CFM)							
		600	800	1000	1200	1400	1600	1800	2000
Input Airflow	0453__X*	415*	415*	480	576	---	---	---	---
	0704__X*	---	---	636*	636*	672	768	---	---
	0905__X*	---	---	---	826*	826*	826*	864	960
	1155__X*	---	---	---	875*	875*	875*	875*	960

		COUNTERFLOW COOLING AIRFLOW REQUIREMENT (CFM)							
		600	800	1000	1200	1400	1600	1800	2000
Input Airflow	0704__X*	---	---	634*	634*	672	768	---	---
	0714__X*								
	0905__X*	---	---	---	819*	819*	819*	864	960
	0915__X*								
1155__X*	---	---	---	860*	860*	860*	864	960	

\*Minimum filter area dictated by heating airflow requirement.

### Disposable Minimum Filter Area (in<sup>2</sup>)

[Based on a 300 ft/min filter face velocity]

# PRODUCT DESIGN

		UPFLOW COOLING AIRFLOW REQUIREMENT (CFM)							
		600	800	1000	1200	1400	1600	1800	2000
Input_Airflow	0453__X*	207*	207*	240	288	---	---	---	---
	0704__X*	---	---	318*	318*	336	384	---	---
	0905__X*	---	---	---	413*	413*	413*	432	480
	1155__X*	---	---	---	437*	437*	437*	432	480

		COUNTERFLOW COOLING AIRFLOW REQUIREMENT (CFM)							
		600	800	1000	1200	1400	1600	1800	2000
Input_Airflow	0704__X*	---	---	316*	316*	336	384	---	---
	0714__X*								
	0905__X*	---	---	---	409*	409*	409*	432	480
	0915__X*								
	1155__X*	---	---	---	430*	430*	430*	432	480

\*Minimum filter area dictated by heating airflow requirement.

## Disposable Minimum Filter Area (in<sup>2</sup>)

[Based on a 600 ft/min filter face velocity]

### Counterflow Filters

Return air filters may be installed at the at the counterflow top return. A field supplied center filter support must be provided by the installer in order to use the top return. The furnace will accommodate the following counterflow top return filter sizes depending on cabinet size:

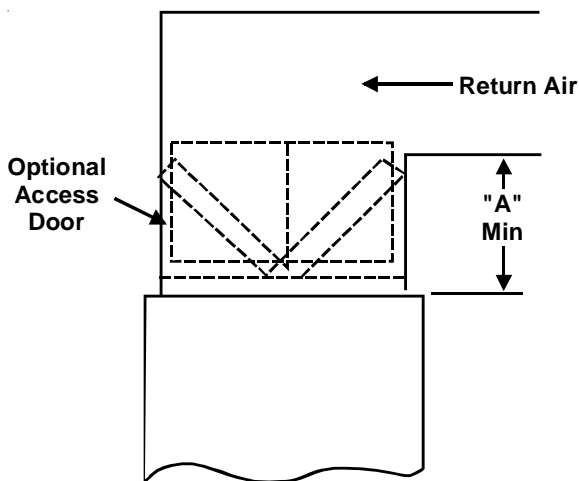

Counterflow Top Return				
Cabinet Width	Filter Area (in <sup>2</sup> )	Qty	Filter Size (in)	Dimension "A" (in)
17 1/2	600	2	15 X 20 X 1	14.2
21				13.0
24 1/2				11.3
17 1/2	800	2	20 X 20 X 1	19.7
21				18.8
24 1/2				17.7
17 1/2	1000	2	25 X 20 X 1	25.0
21				24.3
24 1/2				23.4

Refer to Minimum Filter Area tables to determine filter area requirement. **NOTE:** Filters can also be installed elsewhere in the duct system such as a central return.

# FURNACE SPECIFICATIONS

# GMVC95

MODEL	GMVC950453BX*	GMVC950704CX*	GMVC950905CX*	GMVC950905DX*	GMVC951155DX*
Btuh Input (US) High Fire	46,000	69,000	92,000	92,000	115,000
Output (US) High Fire	44,300	66,900	88,800	88,800	111,100
Btuh Input (US) Low Fire	32,000	48,000	64,000	64,000	80,000
Output (US) Low Fire	30,800	46,400	61,700	61,700	77,400
A.F.U.E.	95%	95%	95%	95%	95%
Rated External Static (" w.c.)	.10 - .50	.10 - .50	.10 - .50	.10 - .50	.10 - .50
Temperature Rise (°F)	30 - 60	30 - 60	30 - 60	30 - 60	35 - 65
High Stage Pressure Switch Trip Point (" w.c.)	-0.75	-0.75	-1.70	-1.10	-1.10
Low Stage Pressure Switch Trip Point (" w.c.)	-0.30	-0.30	-0.60	-0.50	-0.50
Front Cover Pressure Switch Trip Point (" w.c.)	-0.10	-0.10	-0.10	-0.10	-0.10
Blower Wheel (D" x W")	10 x 8	10 x 10	11 x 10	11 x 10	11 x 10
Blower Horsepower	1/2	3/4	1	1	1
Blower Speeds	Refer to airflow charts in this manual.				
Max CFM @ 0.5 E.S.P.					
Power Supply	115-60-1	115-60-1	115-60-1	115-60-1	115-60-1
Minimum Circuit Ampacity (MCA)	11.3	14.1	14.4	14.4	14.4
Maximum Overcurrent Device	15	15	15	15	15
Transformer (VA)	40	40	40	40	40
Heat Anticipator (Amps)	0.7	0.7	0.7	0.7	0.7
Primary Limit Setting (°F)	145	155	130	145	150
Auxiliary Limit Setting (°F)	150	190	120	180	200
Rollout Limit Setting (°F)	170	200	200	190	200
Fan Delay On Heating	30 secs.	30 secs.	30 secs.	30 secs.	30 secs.
Off Heating *	150 secs.	150 secs.	150 secs.	150 secs.	150 secs.
Fan Delay On Cooling	5 secs.	5 secs.	5 secs.	5 secs.	5 secs.
Off Cooling	45 secs.	45 secs.	45 secs.	45 secs.	45 secs.
Fan Delay On - Fan Only	5 secs.	5 secs.	5 secs.	5 secs.	5 secs.
Gas Supply Pressure (Natural/Propane) (" w.c.)	7 / 11	7 / 11	7 / 11	7 / 11	7 / 11
Manifold Pressure (Natural/Propane) High Stage (" w.c.)	3.5 / 10	3.5 / 10	3.5 / 10	3.5 / 10	3.5 / 10
Manifold Pressure (Natural/Propane) Low Stage ("w.c.)	1.9 / 6.0	1.9 / 6.0	1.9 / 6.0	1.9 / 6.0	1.9 / 6.0
Orifice Size (Natural/Propane)	#43 / #55	#43 / #55	#43 / #55	#43 / #55	#43 / #55
Number of Burners	2	3	4	4	5
Vent Connector Diameter (inches)	2	2	2	2	2
Combustion Air Connector Diameter (inches)	2	2	2	2	2
Shipping Weight (lbs.)	133	157	172	172	184

\* Off Heating - This fan delay timing is adjustable (90, 120, 150 or 180 seconds), 150 seconds as shipped.

1. These furnaces are manufactured for natural gas operation. Optional Kits are available for conversion to propane gas operation.
2. For elevations above 2000 ft. the rating should be reduced by 4% for each 1000 ft. above sea level. The furnace must not be derated, orifice changes should only be made if necessary for altitude.
3. The total heat loss from the structure as expressed in TOTAL BTU/HR must be calculated by the manufactures method in accordance with the "A.S.H.R.A.E. GUIDE" or "MANUAL J-LOAD CALCULATIONS" published by the AIR CONDITIONING CONTRACTORS OF AMERICA. The total heat loss calculated should be equal to or less than the heating capacity. Output based on D.O.E. test procedures, steady state efficiency times output.
4. Minimum Circuit Ampacity calculated as: (1.25 x Circulator Blower Amps) + I.D. Blower Amps.



# FURNACE SPECIFICATIONS

# AMVC95

MODEL	AMVC950453BX*	AMVC950704CX*	AMVC950905CX*	AMVC950905DX*	AMVC951155DX*
Btuh Input (US) High Fire	46,000	69,000	92,000	92,000	115,000
Output (US) High Fire	44,300	66,900	88,800	88,800	111,100
Btuh Input (US) Low Fire	32,000	48,000	64,000	64,000	80,000
Output (US) Low Fire	30,800	46,400	61,700	61,700	77,400
A.F.U.E.	99%	95.5%	95.7%	95.7%	95.8%
Rated External Static (" w.c.)	.10 - .50	.10 - .50	.10 - .50	.10 - .50	.10 - .50
Temperature Rise (°F)	30 - 60	30 - 60	30 - 60	30 - 60	35 - 65
High Stage Pressure Switch Trip Point (" w.c.)	-0.75	-0.75	-1.70	-1.10	-1.10
Low Stage Pressure Switch Trip Point (" w.c.)	-0.30	-0.30	-0.60	-0.50	-0.50
Front Cover Pressure Switch Trip Point (" w.c.)	-0.10	-0.10	-0.10	-0.10	-0.10
Blower Wheel (D" x W")	10 x 8	10 x 10	11 x 10	11 x 10	11 x 10
Blower Horsepower	1/2	3/4	1	1	1
Blower Speeds	Refer to airflow charts in this manual.				
Max CFM @ 0.5 E.S.P.					
Power Supply	115-60-1	115-60-1	115-60-1	115-60-1	115-60-1
Minimum Circuit Ampacity (MCA)	11.3	14.1	14.4	14.4	14.4
Maximum Overcurrent Device	15	15	15	15	15
Transformer (VA)	40	40	40	40	40
Heat Anticipator (Amps)	0.7	0.7	0.7	0.7	0.7
Primary Limit Setting (°F)	145	155	130	145	150
Auxiliary Limit Setting (°F)	150	190	120	180	200
Rollout Limit Setting (°F)	170	200	200	190	200
Fan Delay On Heating	30 secs.	30 secs.	30 secs.	30 secs.	30 secs.
Off Heating *	150 secs.	150 secs.	150 secs.	150 secs.	150 secs.
Fan Delay On Cooling	5 secs.	5 secs.	5 secs.	5 secs.	5 secs.
Off Cooling	45 secs.	45 secs.	45 secs.	45 secs.	45 secs.
Fan Delay On - Fan Only	5 secs.	5 secs.	5 secs.	5 secs.	5 secs.
Gas Supply Pressure (Natural/Propane) (" w.c.)	7 / 11	7 / 11	7 / 11	7 / 11	7 / 11
Manifold Pressure (Natural/Propane) High Stage (" w.c.)	3.5 / 10	3.5 / 10	3.5 / 10	3.5 / 10	3.5 / 10
Manifold Pressure (Natural/Propane) Low Stage ("w.c.)	1.9 / 6.0	1.9 / 6.0	1.9 / 6.0	1.9 / 6.0	1.9 / 6.0
Orifice Size (Natural/Propane)	#43 / #55	#43 / #55	#43 / #55	#43 / #55	#43 / #55
Number of Burners	2	3	4	4	5
Vent Connector Diameter (inches)	2	2	2	2	2
Combustion Air Connector Diameter (inches)	2	2	2	2	2
Shipping Weight (lbs.)	133	157	172	172	184

\* Off Heating - This fan delay timing is adjustable (90, 120, 150 or 180 seconds), 150 seconds as shipped.

1. These furnaces are manufactured for natural gas operation. Optional Kits are available for conversion to propane gas operation.
2. For elevations above 2000 ft. the rating should be reduced by 4% for each 1000 ft. above sea level. The furnace must not be derated, orifice changes should only be made if necessary for altitude.
3. The total heat loss from the structure as expressed in TOTAL BTU/HR must be calculated by the manufactures method in accordance with the "A.S.H.R.A.E. GUIDE" or "MANUAL J-LOAD CALCULATIONS" published by the AIR CONDITIONING CONTRACTORS OF AMERICA. The total heat loss calculated should be equal to or less than the heating capacity. Output based on D.O.E. test procedures, steady state efficiency times output.
4. Minimum Circuit Ampacity calculated as: (1.25 x Circulator Blower Amps) + I.D. Blower Amps.

# FURNACE SPECIFICATIONS

# GCVC9

MODEL	GCVC90704CX*	GCVC90905DX*	GCVC91155DX*
Btuh Input (US) High Fire	69,000	92,000	115,000
Output (US) High Fire	65,300	86,500	109,000
Btuh Input (US) Low Fire	48,000	64,000	80,000
Output (US) Low Fire	45,000	60,100	77,400
A.F.U.E.	93.0%	92.0%	93%
Rated External Static (" w.c.)	.10 - .50	.10 - .50	.10 - .50
Temperature Rise (°F)	30 - 60	30 - 60	40 - 70
High Stage Pressure Switch Trip Point (" w.c.)	-0.55	-0.55	-0.55
Low Stage Pressure Switch Trip Point (" w.c.)	-0.20	-0.20	-0.20
Front Cover Pressure Switch Trip Point (" w.c.)	-0.37	-0.37	-0.37
Blower Wheel (D" x W")	10 x 10	11 x 10	11 x 10
Blower Horsepower	3/4	1	1
Blower Speeds	Refer to airflow charts in this manual.		
Max CFM @ 0.5 E.S.P.	Refer to airflow charts in this manual.		
Power Supply	115-60-1	115-60-1	115-60-1
Minimum Circuit Ampacity (MCA)	14.1	14.4	14.4
Maximum Overcurrent Device	15	15	15
Transformer (VA)	40	40	40
Heat Anticipator (Amps)	0.7	0.7	0.7
Primary Limit Setting (°F)	160	170	145
Auxiliary Limit Setting (°F)	220	180	180
Rollout Limit Setting (°F)	220	210	210
Fan Delay On Heating	30 secs.	30 secs.	30 secs.
Off Heating *	150 secs.	150 secs.	150 secs.
Fan Delay On Cooling	5 secs.	5 secs.	5 secs.
Off Cooling	45 secs.	45 secs.	45 secs.
Fan Delay On - Fan Only	5 secs.	5 secs.	5 secs.
Gas Supply Pressure (Natural/Propane) (" w.c.)	7 / 11	7 / 11	7 / 11
Manifold Pressure (Natural/Propane) High Stage (" w.c.)	3.5 / 10	3.5 / 10	3.5 / 10
Manifold Pressure (Natural/Propane) Low Stage ("w.c.)	1.9 / 6.0	1.9 / 6.0	1.9 / 6.0
Orifice Size (Natural/Propane)	#43 / #55	#43 / #55	#43 / #55
Number of Burners	3	4	5
Vent Connector Diameter (inches)	2	2	2
Combustion Air Connector Diameter (inches)	2	2	2
Shipping Weight (lbs.)	157	172	175

\* Off Heating - This fan delay timing is adjustable (90, 120, 150 or 180 seconds), 150 seconds as shipped.

1. These furnaces are manufactured for natural gas operation. Optional Kits are available for conversion to propane gas operation.
2. For elevations above 2000 ft. the rating should be reduced by 4% for each 1000 ft. above sea level. The furnace must not be derated, orifice changes should only be made if necessary for altitude.
3. The total heat loss from the structure as expressed in TOTAL BTU/HR must be calculated by the manufactures method in accordance with the "A.S.H.R.A.E. GUIDE" or "MANUAL J-LOAD CALCULATIONS" published by the AIR CONDITIONING CONTRACTORS OF AMERICA. The total heat loss calculated should be equal to or less than the heating capacity. Output based on D.O.E. test procedures, steady state efficiency times output.
4. Minimum Circuit Ampacity calculated as: (1.25 x Circulator Blower Amps) + I.D. Blower Amps.

# FURNACE SPECIFICATIONS

# GVCV95

MODEL	GVCV950714CX*	GVCV950915DX*
Btuh Input (US) High Fire	69,000	92,000
Output (US) High Fire	65,300	86,500
Btuh Input (US) Low Fire	48,000	64,000
Output (US) Low Fire	45,000	60,100
A.F.U.E.	95.0%	95.0%
Rated External Static (" w.c.)	.10 - .50	.10 - .50
Temperature Rise (°F)	25 - 55	25 - 55
High Stage Pressure Switch Trip Point (" w.c.)	-1.60	-1.60
Low Stage Pressure Switch Trip Point (" w.c.)	-0.80	-0.80
Front Cover Pressure Switch Trip Point (" w.c)	-0.10	-0.10
Blower Wheel (D" x W")	10 x 10	11 x 10
Blower Horsepower	3/4	1
Blower Speeds	Refer to airflow charts in this manual.	
Max CFM @ 0.5 E.S.P.		
Power Supply	115-60-1	115-60-1
Minimum Circuit Ampacity (MCA)	11.2	15.0
Maximum Overcurrent Device	15	15
Transformer (VA)	40	40
Heat Anticipator (Amps)	0.7	0.7
Primary Limit Setting (°F)	150	130
Auxiliary Limit Setting (°F)	120	120
Rollout Limit Setting (°F)	210	210
Fan Delay On Heating	30 secs.	30 secs.
Off Heating *	150 secs.	150 secs.
Fan Delay On Cooling	5 secs.	5 secs.
Off Cooling	45 secs.	45 secs.
Fan Delay On - Fan Only	5 secs.	5 secs.
Gas Supply Pressure (Natural/Propane) (" w.c.)	7 / 11	7 / 11
Manifold Pressure (Natural/Propane) High Stage (" w.c.)	3.5 / 10	3.5 / 10
Manifold Pressure (Natural/Propane) Low Stage ("w.c.)	1.9 / 6.0	1.9 / 6.0
Orifice Size (Natural/Propane)	#43 / #55	#43 / #55
Number of Burners	3	4
Vent Connector Diameter (inches)	2	2
Combustion Air Connector Diameter (inches)	2	2
Shipping Weight (lbs.)	157	172

\* Off Heating - This fan delay timing is adjustable (90, 120, 150 or 180 seconds), 150 seconds as shipped.

1. These furnaces are manufactured for natural gas operation. Optional Kits are available for conversion to propane gas operation.
2. For elevations above 2000 ft. the rating should be reduced by 4% for each 1000 ft. above sea level. The furnace must not be derated, orifice changes should only be made if necessary for altitude.
3. The total heat loss from the structure as expressed in TOTAL BTU/HR must be calculated by the manufactures method in accordance with the "A.S.H.R.A.E. GUIDE" or "MANUAL J-LOAD CALCULATIONS" published by the AIR CONDITIONING CONTRACTORS OF AMERICA. The total heat loss calculated should be equal to or less than the heating capacity. Output based on D.O.E. test procedures, steady state efficiency times output.
4. Minimum Circuit Ampacity calculated as: (1.25 x Circulator Blower Amps) + I.D. Blower Amps.

# FURNACE SPECIFICATIONS

# ACVC9

MODEL	ACVC90704CX*	ACVC90905DX*
Btuh Input (US) High Fire	69,000	92,000
Output (US) High Fire	65,300	86,500
Btuh Input (US) Low Fire	48,000	64,000
Output (US) Low Fire	45,000	60,100
A.F.U.E.	93.3%	92.7%
Rated External Static (" w.c.)	.10 - .50	.10 - .50
Temperature Rise (°F)	30 - 60	30 - 60
High Stage Pressure Switch Trip Point (" w.c.)	-0.55	-0.55
Low Stage Pressure Switch Trip Point (" w.c.)	-0.20	-0.20
Front Cover Pressure Switch Trip Point (" w.c.)	-0.37	-0.37
Blower Wheel (D" x W")	10 x 10	11 x 10
Blower Horsepower	3/4	1
Blower Speeds	Refer to airflow charts in this manual.	
Max CFM @ 0.5 E.S.P.		
Power Supply	115-60-1	115-60-1
Minimum Circuit Ampacity (MCA)	14.1	14.4
Maximum Overcurrent Device	15	15
Transformer (VA)	40	40
Heat Anticipator (Amps)	0.7	0.7
Primary Limit Setting (°F)	160	170
Auxiliary Limit Setting (°F)	220	180
Rollout Limit Setting (°F)	220	210
Fan Delay On Heating	30 secs.	30 secs.
Off Heating *	150 secs.	150 secs.
Fan Delay On Cooling	5 secs.	5 secs.
Off Cooling	45 secs.	45 secs.
Fan Delay On - Fan Only	5 secs.	5 secs.
Gas Supply Pressure (Natural/Propane) (" w.c.)	7 / 11	7 / 11
Manifold Pressure (Natural/Propane) High Stage (" w.c.)	3.5 / 10	3.5 / 10
Manifold Pressure (Natural/Propane) Low Stage ("w.c.)	1.9 / 6.0	1.9 / 6.0
Orifice Size (Natural/Propane)	#43 / #55	#43 / #55
Number of Burners	3	4
Vent Connector Diameter (inches)	2	2
Combustion Air Connector Diameter (inches)	2	2
Shipping Weight (lbs.)	157	172

\* Off Heating - This fan delay timing is adjustable (90, 120, 150 or 180 seconds), 150 seconds as shipped.

1. These furnaces are manufactured for natural gas operation. Optional Kits are available for conversion to propane gas operation.
2. For elevations above 2000 ft. the rating should be reduced by 4% for each 1000 ft. above sea level. The furnace must not be derated, orifice changes should only be made if necessary for altitude.
3. The total heat loss from the structure as expressed in TOTAL BTU/HR must be calculated by the manufactures method in accordance with the "A.S.H.R.A.E. GUIDE" or "MANUAL J-LOAD CALCULATIONS" published by the AIR CONDITIONING CONTRACTORS OF AMERICA. The total heat loss calculated should be equal to or less than the heating capacity. Output based on D.O.E. test procedures, steady state efficiency times output.
4. Minimum Circuit Ampacity calculated as: (1.25 x Circulator Blower Amps) + I.D. Blower Amps.

# FURNACE SPECIFICATIONS

# ACVC95

MODEL	ACVC950714CX*	ACVC950915DX*
Btuh Input (US) High Fire	69,000	92,000
Output (US) High Fire	65,300	86,500
Btuh Input (US) Low Fire	48,000	64,000
Output (US) Low Fire	45,000	60,100
A.F.U.E.	95.0%	95.0%
Rated External Static (" w.c.)	.10 - .50	.10 - .50
Temperature Rise (°F)	25 - 55	25 - 55
High Stage Pressure Switch Trip Point (" w.c.)	-1.60	-1.60
Low Stage Pressure Switch Trip Point (" w.c.)	-0.80	-0.80
Front Cover Pressure Switch Trip Point (" w.c.)	-0.10	-0.10
Blower Wheel (D" x W")	10 x 10	11 x 10
Blower Horsepower	3/4	1
Blower Speeds	Refer to airflow charts in this manual.	
Max CFM @ 0.5 E.S.P.		
Power Supply	115-60-1	115-60-1
Minimum Circuit Ampacity (MCA)	11.2	15.0
Maximum Overcurrent Device	15	15
Transformer (VA)	40	40
Heat Anticipator (Amps)	0.7	0.7
Primary Limit Setting (°F)	150	130
Auxiliary Limit Setting (°F)	120	120
Rollout Limit Setting (°F)	210	210
Fan Delay On Heating	30 secs.	30 secs.
Off Heating *	150 secs.	150 secs.
Fan Delay On Cooling	5 secs.	5 secs.
Off Cooling	45 secs.	45 secs.
Fan Delay On - Fan Only	5 secs.	5 secs.
Gas Supply Pressure (Natural/Propane) (" w.c.)	7 / 11	7 / 11
Manifold Pressure (Natural/Propane) High Stage (" w.c.)	3.5 / 10	3.5 / 10
Manifold Pressure (Natural/Propane) Low Stage ("w.c.)	1.9 / 6.0	1.9 / 6.0
Orifice Size (Natural/Propane)	#43 / #55	#43 / #55
Number of Burners	3	4
Vent Connector Diameter (inches)	2	2
Combustion Air Connector Diameter (inches)	2	2
Shipping Weight (lbs.)	157	172

\* Off Heating - This fan delay timing is adjustable (90, 120, 150 or 180 seconds), 150 seconds as shipped.

1. These furnaces are manufactured for natural gas operation. Optional Kits are available for conversion to propane gas operation.
2. For elevations above 2000 ft. the rating should be reduced by 4% for each 1000 ft. above sea level. The furnace must not be derated, orifice changes should only be made if necessary for altitude.
3. The total heat loss from the structure as expressed in TOTAL BTU/HR must be calculated by the manufactures method in accordance with the "A.S.H.R.A.E. GUIDE" or "MANUAL J-LOAD CALCULATIONS" published by the AIR CONDITIONING CONTRACTORS OF AMERICA. The total heat loss calculated should be equal to or less than the heating capacity. Output based on D.O.E. test procedures, steady state efficiency times output.
4. Minimum Circuit Ampacity calculated as: (1.25 x Circulator Blower Amps) + I.D. Blower Amps.

# BLOWER PERFORMANCE SPECIFICATIONS

## GMVC95/AMVC95 Heating Speed Charts

GMVC950453BX* AMVC950453BX* (Rise Range: 30 - 60°F)					GMVC950704CX* AMVC950704CX* (Rise Range: 30 - 60°F)				
Heating Speed Tap	Adjust Tap	Low Stage CFM at .1" - .5" w.c. ESP	High Stage CFM at .1" - .5" w.c. ESP	Rise (°F)	Heating Speed Tap	Adjust Tap	Low Stage CFM at .1" - .5" w.c. ESP	High Stage CFM at .1" - .5" w.c. ESP	Rise (°F)
A	Minus(-)	495	713	57	A	Minus(-)	756	1089	56
	Normal	550	792	41		Normal	840	1210	50
	Plus (+)	605	871	46		Plus (+)	924	1331	46
B	Minus(-)	540	778	52	B	Minus(-)	828	1192	51
	Normal	600	864	47		Normal	920	1325	46
	Plus (+)	660	950	43		Plus (+)	1012	1457	42
C	Minus(-)	585	842	48	C	Minus(-)	900	1296	47
	Normal	650	936	43		Normal	1000	1440	42
	Plus (+)	715	1030	39		Plus (+)	1100	1584	38
D	Minus(-)	630	907	45	D	Minus(-)	972	1400	43
	Normal	700	1008	40		Normal	1080	1555	39
	Plus (+)	770	1109	36		Plus (+)	1188	1711	35

GMVC950905CX* AMVC950905CX* (Rise Range: 30 - 60°F)				
Heating Speed Tap	Adjust Tap	Low Stage CFM at .1" - .5" w.c. ESP	High Stage CFM at .1" - .5" w.c. ESP	Rise (°F)
A	Minus(-)	945	1341	60
	Normal	1050	1490	54
	Plus (+)	1155	1639	49
B	Minus(-)	1008	1413	57
	Normal	1120	1570	51
	Plus (+)	1232	1727	47
C	Minus(-)	1080	1521	53
	Normal	1200	1690	48
	Plus (+)	1320	1859	43
D	Minus(-)	1125	1602	50
	Normal	1250	1780	45
	Plus (+)	1375	1958	41

- Units are shipped without filter(s). CFM in chart is without filter(s).
- All furnaces shipped with heating speed set at "B" and cooling speed set at "D". Installer should adjust blower speed as needed. The first task is to determine the proper airflow for the cooling system.
- For most cooling applications, about 400 CFM per ton is desirable.
- The chart is for information only. For satisfactory operation, external static pressure not to exceed value shown on rating plate.
- Do not operate above 0.5" w.c. ESP in heating mode. Operating between 0.5" w.c. and 0.8" w.c. is tabulated for cooling purposes only.
- \* Motor CFM minimum.

# BLOWER PERFORMANCE SPECIFICATIONS

## GMVC95/AMVC95 Heating Speed Charts

GMVC950905DX* AMVC950905DX* (Rise Range: 30 - 60°F)					GMVC951155DX* AMVC951155DX* (Rise Range: 35 - 65°F)				
Heating Speed Tap	Adjust Tap	Low Stage CFM at .1" - .5" w.c. ESP	High Stage CFM at .1" - .5" w.c. ESP	Rise (°F)	Heating Speed Tap	Adjust Tap	Low Stage CFM at .1" - .5" w.c. ESP	High Stage CFM at .1" - .5" w.c. ESP	Rise (°F)
A	Minus(-)	1013	1458	56	A	Minus(-)	1107	1594	63
	Normal	1125	1620	50		Normal	1230	1771	57
	Plus (+)	1238	1782	45		Plus (+)	1353	1948	52
B	Minus(-)	1076	1549	52	B	Minus(-)	1139	1639	62
	Normal	1195	1721	47		Normal	1265	1822	56
	Plus (+)	1315	1893	43		Plus (+)	1392	2004	50
C	Minus(-)	1139	1639	49	C	Minus(-)	1170	1685	60
	Normal	1265	1822	44		Normal	1300	1872	54
	Plus (+)	1392	2004	40		Plus (+)	1430	2059	49
D	Minus(-)	1202	1730	47	D	Minus(-)	1202	1730	58
	Normal	1335	1922	42		Normal	1335	1922	53
	Plus (+)	1469	2115	38		Plus (+)	1469	2115	48

1. Units are shipped without filter(s). CFM in chart is without filter(s).
2. All furnaces shipped with heating speed set at "B" and cooling speed set at "D". Installer should adjust blower speed as needed. The first task is to determine the proper airflow for the cooling system.
3. For most cooling applications, about 400 CFM per ton is desirable.
4. The chart is for information only. For satisfactory operation, external static pressure not to exceed value shown on rating plate.
5. Do not operate above 0.5" w.c. ESP in heating mode. Operating between 0.5" w.c. and 0.8" w.c. is tabulated for cooling purposes only.
6. \* Motor CFM minimum.

# BLOWER PERFORMANCE SPECIFICATIONS

## GMVC95/AMVC95 High (Single) Stage Cooling Speed Charts

GMVC950453BX* AMVC950453BX*			GMVC950704CX* AMVC950704CX*			GMVC950905CX* AMVC950905CX*		
Cooling Speed Tap	Adjust Tap	CFM at .1" - .8" w.c. ESP	Cooling Speed Tap	Adjust Tap	CFM at .1" - .8" w.c. ESP	Cooling Speed Tap	Adjust Tap	CFM at .1" - .8" w.c. ESP
A	Minus (-)	540	A	Minus (-)	540	A	Minus (-)	729
	Normal	600		Normal	600		Normal	810
	Plus (+)	660		Plus (+)	660		Plus (+)	891
B	Minus (-)	720	B	Minus (-)	720	B	Minus (-)	990
	Normal	800		Normal	800		Normal	1100
	Plus (+)	880		Plus (+)	880		Plus (+)	1210
C	Minus (-)	900	C	Minus (-)	990	C	Minus (-)	1323
	Normal	1000		Normal	1100		Normal	1470
	Plus (+)	1100		Plus (+)	1210		Plus (+)	1617
D	Minus (-)	1080	D	Minus (-)	1286	D	Minus (-)	1629
	Normal	1200		Normal	1429		Normal	1810
	Plus (+)	1320		Plus (+)	1572		Plus (+)	1991

GMVC950905DX* AMVC950905DX*			GMVC951155DX* AMVC951155DX*		
Cooling Speed Tap	Adjust Tap	CFM at .1" - .8" w.c. ESP	Cooling Speed Tap	Adjust Tap	CFM at .1" - .8" w.c. ESP
A	Minus (-)	720	A	Minus (-)	720
	Normal	800		Normal	800
	Plus (+)	880		Plus (+)	880
B	Minus (-)	990	B	Minus (-)	990
	Normal	1100		Normal	1100
	Plus (+)	1210		Plus (+)	1210
C	Minus (-)	1260	C	Minus (-)	1260
	Normal	1400		Normal	1400
	Plus (+)	1540		Plus (+)	1540
D	Minus (-)	1620	D	Minus (-)	1620
	Normal	1800		Normal	1800
	Plus (+)	1980		Plus (+)	1980

1. Units are shipped without filter(s). CFM in chart is without filter(s).
2. All furnaces shipped with heating speed set at "B" and cooling speed set at "D". Installer should adjust blower speed as needed. The first task is to determine the proper airflow for the cooling system.
3. For most cooling applications, about 400 CFM per ton is desirable.
4. The chart is for information only. For satisfactory operation, external static pressure not to exceed value shown on rating plate.
5. Do not operate above 0.5" w.c. ESP in heating mode. Operating between 0.5" w.c. and 0.8" w.c. is tabulated for cooling purposes only.
6. \* Motor CFM minimum.



# BLOWER PERFORMANCE SPECIFICATIONS

## GMVC95/AMVC95 Low Stage Cooling Speed Charts

GMVC950453BX* AMVC950453BX*			GMVC950704CX* AMVC950704CX*			GMVC950905CX* AMVC950905CX*		
Cooling Speed Tap	Adjust Tap	CFM at .1" - .8" w.c. ESP	Cooling Speed Tap	Adjust Tap	CFM at .1" - .8" w.c. ESP	Cooling Speed Tap	Adjust Tap	CFM at .1" - .8" w.c. ESP
A	Minus(-)	351	A	Minus(-)	351	A	Minus(-)	495
	Normal	390		Normal	390		Normal	550
	Plus (+)	429		Plus (+)	429		Plus (+)	605
B	Minus(-)	468	B	Minus(-)	468	B	Minus(-)	693
	Normal	520		Normal	520		Normal	770
	Plus (+)	572		Plus (+)	572		Plus (+)	847
C	Minus(-)	585	C	Minus(-)	644	C	Minus(-)	900
	Normal	650		Normal	715		Normal	1000
	Plus (+)	715		Plus (+)	787		Plus (+)	1100
D	Minus(-)	702	D	Minus(-)	836	D	Minus(-)	1125
	Normal	780		Normal	929		Normal	1250
	Plus (+)	858		Plus (+)	1022		Plus (+)	1375

GMVC950905DX* AMVC950905DX*			GMVC951155DX* AMVC951155DX*		
Cooling Speed Tap	Adjust Tap	CFM at .1" - .8" w.c. ESP	Cooling Speed Tap	Adjust Tap	CFM at .1" - .8" w.c. ESP
A	Minus(-)	468	A	Minus(-)	468
	Normal	520		Normal	520
	Plus (+)	572		Plus (+)	572
B	Minus(-)	644	B	Minus(-)	644
	Normal	715		Normal	715
	Plus (+)	787		Plus (+)	787
C	Minus(-)	819	C	Minus(-)	819
	Normal	910		Normal	910
	Plus (+)	1001		Plus (+)	1001
D	Minus(-)	1053	D	Minus(-)	1053
	Normal	1170		Normal	1170
	Plus (+)	1287		Plus (+)	1287

- Units are shipped without filter(s). CFM in chart is without filter(s).
- All furnaces shipped with heating speed set at "B" and cooling speed set at "D". Installer should adjust blower speed as needed. The first task is to determine the proper airflow for the cooling system.
- For most cooling applications, about 400 CFM per ton is desirable.
- The chart is for information only. For satisfactory operation, external static pressure not to exceed value shown on rating plate.
- Do not operate above 0.5" w.c. ESP in heating mode. Operating between 0.5" w.c. and 0.8" w.c. is tabulated for cooling purposes only.
- \* Motor CFM minimum.

# BLOWER PERFORMANCE SPECIFICATIONS

## GMVC95/AMVC95 Continuous Fan Speed Chart

Model	Furnace Maximum CFM	Continuous Fan Speed <sup>1,2</sup>
GMVC950453BX* AMVC950453BX*	1400	420
GMVC950704CX* AMVC950704CX*	1760	530
GMVC950905CX* AMVC950905CX*	2200	660
GMVC950905DX* AMVC950905DX*	2200	660
GMVC951155DX* AMVC951155DX*	2200	660

<sup>1</sup> Continuous fan speed is 30% of furnace maximum CFM

<sup>2</sup> Three continuous fan speeds are possible with the CTK01AA thermostat: 30%, 50%, and 70% of furnace maximum CFM

## GCVC9/ACVC9 Continuous Fan Speed Chart

Model	Furnace Maximum CFM	Continuous Fan Speed <sup>1,2</sup>
GCVC90704CX* ACVC90704CX*	1760	530
GCVC90905DX* ACVC90905DX*	2200	660
GCVC91155DX*	2350	705

<sup>1</sup> Continuous fan speed is 30% of furnace maximum CFM

<sup>2</sup> Three continuous fan speeds are possible with the CTK01AA thermostat: 30%, 50%, and 70% of furnace maximum CFM.

## GCVC95/ACVC95 Continuous Fan Speed Chart

Model	Furnace Maximum CFM	Continuous Fan Speed <sup>1,2</sup>
GCVC950714CX* ACVC950714CX*	1760	530
GCVC950915DX* ACVC950915DX*	2200	660

<sup>1</sup> Continuous fan speed is 30% of furnace maximum CFM

<sup>2</sup> Three continuous fan speeds are possible with the CTK01AA thermostat: 30%, 50%, and 70% of furnace maximum CFM.

- Units are shipped without filter(s). CFM in chart is without filter(s).
- All furnaces shipped with heating speed set at "B" and cooling speed set at "D". Installer should adjust blower speed as needed. The first task is to determine the proper airflow for the cooling system.
- For most cooling applications, about 400 CFM per ton is desirable.
- The chart is for information only. For satisfactory operation, external static pressure not to exceed value shown on rating plate.
- Do not operate above 0.5" w.c. ESP in heating mode. Operating between 0.5" w.c. and 0.8" w.c. is tabulated for cooling purposes only.
- \* Motor CFM minimum.

# BLOWER PERFORMANCE SPECIFICATIONS

## GCVC9/ACVC9 Heating Speed Charts

GCVC90704CX* ACVC90704CX* (Rise Range: 30 - 60°F)					GCVC90905DX* ACVC90905DX* (Rise Range: 30 - 60°F)				
Heating Speed Tap	Adjust Tap	Low Stage CFM at .1" - .5" w.c. ESP	High Stage CFM at .1" - .5" w.c. ESP	Rise (°F)	Heating Speed Tap	Adjust Tap	Low Stage CFM at .1" - .5" w.c. ESP	High Stage CFM at .1" - .5" w.c. ESP	Rise (°F)
A	Minus(-)	747	1,076	56	A	Minus(-)	999	1,439	56
	Normal	830	1,195	50		Normal	1,110	1,598	50
	Plus (+)	913	1,315	46		Plus (+)	1,221	1,758	46
B	Minus(-)	824	1,186	51	B	Minus(-)	1,067	1,536	52
	Normal	915	1,318	46		Normal	1,185	1,706	47
	Plus (+)	1,007	1,449	42		Plus (+)	1,303	1,876	43
C	Minus(-)	900	1,296	47	C	Minus(-)	1,134	1,633	49
	Normal	1,000	1,440	42		Normal	1,260	1,814	44
	Plus (+)	1,100	1,584	38		Plus (+)	1,386	1,996	40
D	Minus(-)	978	1,408	43	D	Minus(-)	1,202	1,730	46
	Normal	1,085	1,562	39		Normal	1,335	1,922	42
	Plus (+)	1,194	1,719	35		Plus (+)	1,469	2,115	38

GCVC91155DX* (Rise Range: 40 - 70°F)				
Heating Speed Tap	Adjust Tap	Low Stage CFM at .1" - .5" w.c. ESP	High Stage CFM at .1" - .5" w.c. ESP	Rise (°F)
A	Minus(-)	1,093	1,583	63
	Normal	1,214	1,759	56
	Plus (+)	1,335	1,935	51
B	Minus(-)	1,106	1,612	61
	Normal	1,229	1,791	55
	Plus (+)	1,352	1,970	50
C	Minus(-)	1,166	1,654	60
	Normal	1,296	1,838	54
	Plus (+)	1,426	2,022	49
D	Minus(-)	1,172	1,690	59
	Normal	1,302	1,878	53
	Plus (+)	1,432	2,066	48

1. Units are shipped without filter(s). CFM in chart is without filter(s).
2. All furnaces shipped with heating speed set at "B" and cooling speed set at "D". Installer should adjust blower speed as needed. The first task is to determine the proper airflow for the cooling system.
3. For most cooling applications, about 400 CFM per ton is desirable.
4. The chart is for information only. For satisfactory operation, external static pressure not to exceed value shown on rating plate.
5. Do not operate above 0.5" w.c. ESP in heating mode. Operating between 0.5" w.c. and 0.8" w.c. is tabulated for cooling purposes only.
6. \* Motor CFM minimum.

# BLOWER PERFORMANCE SPECIFICATIONS

## GCVC95/ACVC95 Heating Speed Charts

GCVC950714CX* ACVC950714CX* (Rise Range: 25 - 55°F)					GCVC950915DX* ACVC950915DX* (Rise Range: 25 - 55°F)				
Heating Speed Tap	Adjust Tap	Low Stage CFM at .1" - .5" w.c. ESP	High Stage CFM at .1" - .5" w.c. ESP	Rise (°F)	Heating Speed Tap	Adjust Tap	Low Stage CFM at .1" - .5" w.c. ESP	High Stage CFM at .1" - .5" w.c. ESP	Rise (°F)
A	Minus(-)	783	1107	55	A	Minus(-)	1008	1458	55
	Normal	870	1230	49		Normal	1120	1620	50
	Plus (+)	957	1353	45		Plus (+)	1232	1782	45
B	Minus(-)	855	1215	50	B	Minus(-)	1098	1575	51
	Normal	950	1350	45		Normal	1220	1750	46
	Plus (+)	1045	1485	41		Plus (+)	1342	1925	42
C	Minus(-)	936	1323	46	C	Minus(-)	1152	1674	48
	Normal	1040	1470	41		Normal	1280	1860	43
	Plus (+)	1144	1617	37		Plus (+)	1408	2046	39
D	Minus(-)	1017	1440	42	D	Minus(-)	1206	1773	45
	Normal	1130	1600	38		Normal	1340	1970	41
	Plus (+)	1243	1760	34		Plus (+)	1474	2167	37

- Units are shipped without filter(s). CFM in chart is without filter(s).
- All furnaces shipped with heating speed set at "B" and cooling speed set at "D". Installer should adjust blower speed as needed. The first task is to determine the proper airflow for the cooling system.
- For most cooling applications, about 400 CFM per ton is desirable.
- The chart is for information only. For satisfactory operation, external static pressure not to exceed value shown on rating plate.
- Do not operate above 0.5" w.c. ESP in heating mode. Operating between 0.5" w.c. and 0.8" w.c. is tabulated for cooling purposes only.
- \* Motor CFM minimum.

# BLOWER PERFORMANCE SPECIFICATIONS

## GCVC9/ACVC9 High (Single) Stage Cooling Speed Charts

GCVC90704CX* ACVC90704CX*			GCVC90905DX* ACVC90905DX*		
Cooling Speed Tap	Adjust Tap	CFM at .1" - .8" w.c. ESP	Cooling Speed Tap	Adjust Tap	CFM at .1" - .8" w.c. ESP
A	Minus(-)	540	A	Minus(-)	720
	Normal	600		Normal	800
	Plus (+)	660		Plus (+)	880
B	Minus(-)	720	B	Minus(-)	990
	Normal	800		Normal	1100
	Plus (+)	880		Plus (+)	1210
C	Minus(-)	990	C	Minus(-)	1260
	Normal	1100		Normal	1400
	Plus (+)	1210		Plus (+)	1540
D	Minus(-)	1286	D	Minus(-)	1620
	Normal	1429		Normal	1800
	Plus (+)	1572		Plus (+)	1980

GCVC91155DX*		
Cooling Speed Tap	Adjust Tap	CFM at .1" - .8" w.c. ESP
A	Minus(-)	705
	Normal	783
	Plus (+)	861
B	Minus(-)	982
	Normal	1091
	Plus (+)	1200
C	Minus(-)	1265
	Normal	1406
	Plus (+)	1547
D	Minus(-)	1628
	Normal	1809
	Plus (+)	1990

## GCVC9/ACVC9 Low Stage Cooling Speed Charts

GCVC90704CX* ACVC90704CX*			GCVC90905DX* ACVC90905DX*		
Cooling Speed Tap	Adjust Tap	CFM at .1" - .8" w.c. ESP	Cooling Speed Tap	Adjust Tap	CFM at .1" - .8" w.c. ESP
A	Minus(-)	351	A	Minus(-)	468
	Normal	390		Normal	520
	Plus (+)	429		Plus (+)	572
B	Minus(-)	468	B	Minus(-)	644
	Normal	520		Normal	715
	Plus (+)	572		Plus (+)	787
C	Minus(-)	644	C	Minus(-)	819
	Normal	715		Normal	910
	Plus (+)	787		Plus (+)	1001
D	Minus(-)	836	D	Minus(-)	1053
	Normal	929		Normal	1170
	Plus (+)	1022		Plus (+)	1287

GCVC91155DX*		
Cooling Speed Tap	Adjust Tap	CFM at .1" - .8" w.c. ESP
A	Minus(-)	457
	Normal	508
	Plus (+)	559
B	Minus(-)	621
	Normal	690
	Plus (+)	759
C	Minus(-)	815
	Normal	906
	Plus (+)	997
D	Minus(-)	1049
	Normal	1165
	Plus (+)	1282

- Units are shipped without filter(s). CFM in chart is without filter(s).
- All furnaces shipped with heating speed set at "B" and cooling speed set at "D". Installer should adjust blower speed as needed. The first task is to determine the proper airflow for the cooling system.
- For most cooling applications, about 400 CFM per ton is desirable.
- The chart is for information only. For satisfactory operation, external static pressure not to exceed value shown on rating plate.
- Do not operate above 0.5" w.c. ESP in heating mode. Operating between 0.5" w.c. and 0.8" w.c. is tabulated for cooling purposes only.
- \* Motor CFM minimum.

# BLOWER PERFORMANCE SPECIFICATIONS

## GCVC95/ACVC95 High (Single) Stage Cooling Speed Charts

GCVC950714CX* ACVC950714CX*			GCVC950915DX* ACVC950915DX*		
Cooling Speed Tap	Adjust Tap	CFM at .1" - .8" w.c. ESP	Cooling Speed Tap	Adjust Tap	CFM at .1" - .8" w.c. ESP
A	Minus(-)	594	A	Minus(-)	729
	Normal	660		Normal	810
	Plus (+)	726		Plus (+)	891
B	Minus(-)	747	B	Minus(-)	999
	Normal	830		Normal	1110
	Plus (+)	913		Plus (+)	1221
C	Minus(-)	1017	C	Minus(-)	1287
	Normal	1130		Normal	1430
	Plus (+)	1243		Plus (+)	1573
D	Minus(-)	1314	D	Minus(-)	1674
	Normal	1460		Normal	1860
	Plus (+)	1606		Plus (+)	2046

## GCVC95/ACVC95 Low Stage Cooling Speed Charts

GCVC950714CX* ACVC950714CX*			GCVC950915DX* ACVC950915DX*		
Cooling Speed Tap	Adjust Tap	CFM at .1" - .8" w.c. ESP	Cooling Speed Tap	Adjust Tap	CFM at .1" - .8" w.c. ESP
A	Minus(-)	378	A	Minus(-)	504
	Normal	420		Normal	560
	Plus (+)	462		Plus (+)	616
B	Minus(-)	531	B	Minus(-)	666
	Normal	590		Normal	740
	Plus (+)	649		Plus (+)	814
C	Minus(-)	702	C	Minus(-)	828
	Normal	780		Normal	920
	Plus (+)	858		Plus (+)	1012
D	Minus(-)	864	D	Minus(-)	1071
	Normal	960		Normal	1190
	Plus (+)	1056		Plus (+)	1309

- Units are shipped without filter(s). CFM in chart is without filter(s).
- All furnaces shipped with heating speed set at "B" and cooling speed set at "D". Installer should adjust blower speed as needed. The first task is to determine the proper airflow for the cooling system.
- For most cooling applications, about 400 CFM per ton is desirable.
- The chart is for information only. For satisfactory operation, external static pressure not to exceed value shown on rating plate.
- Do not operate above 0.5" w.c. ESP in heating mode. Operating between 0.5" w.c. and 0.8" w.c. is tabulated for cooling purposes only.
- \* Motor CFM minimum.

# BLOWER PERFORMANCE SPECIFICATIONS

## Circulator Blower Speed Adjustment Switches

Switch Bank: S3		
Cooling Speed Taps	DIP Switch No.	
	1	2
A	OFF	OFF
B	ON	OFF
C	OFF	ON
D*	ON	ON
(*Indicates factory setting)		

Switch Bank: S3		
Adjust Taps	DIP Switch No.	
	3	4
Normal*	OFF	OFF
10%	ON	OFF
-10%	OFF	ON
Normal	ON	ON
(*Indicates factory setting)		

Switch Bank: S4		
Heating Speed Taps	DIP Switch No.	
	7	8
A	OFF	OFF
B*	ON	OFF
C	OFF	ON
D	ON	ON
(*Indicates factory setting)		

**Note:** There are dual 7-segment LED's adjacent to the selection dipswitches. The airflow rounded to the nearest 100 CFM, is displayed on the dual 7-segment LED's. The CFM display alternates with the operating mode.

Example:

If the airflow demand is 1230 CFM, the LED's will display 12. If the airflow demand is 1275 CFM, the LED's will display 13.

**Note:** Continuous fan speed will be 30% of the furnace's maximum airflow capability. If the furnace maximum CFM capability is 1760 CFM, the continuous fan speed will be  $0.30 \times 1760 \text{ CFM} = 530 \text{ CFM}$ .

Example: If the furnace maximum CFM capability is 1760 CFM, the continuous fan speed will be  $0.30 \times 1760 \text{ CFM} = 530 \text{ CFM}$ .

## Dehumidification Enable Switch

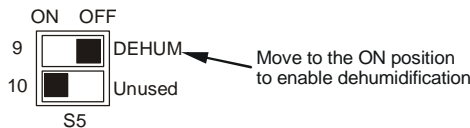

**Note:** The optional usage of a dehumidistat allows the furnace's circulator blower to operate at a slightly lower speed (85% of desired speed) during a combined thermostat call for cooling and dehumidistat call for dehumidification. This can be done through an independent dehumidistat or through a thermostat's DEHUM terminal (if available). This lower blower speed enhances dehumidification of the conditioned air as it passes through the AC coil. For proper function, a dehumidistat applied to this furnace must operate on 24 VAC and utilize a switch which *opens on humidity rise*.

1. Units are shipped without filter(s). CFM in chart is without filter(s).
2. All furnaces shipped with heating speed set at "B" and cooling speed set at "D". Installer should adjust blower speed as needed. The first task is to determine the proper airflow for the cooling system.
3. For most cooling applications, about 400 CFM per ton is desirable.
4. The chart is for information only. For satisfactory operation, external static pressure not to exceed value shown on rating plate.
5. Do not operate above 0.5" w.c. ESP in heating mode. Operating between 0.5" w.c. and 0.8" w.c. is tabulated for cooling purposes only.
6. \* Motor CFM minimum.

# BLOWER PERFORMANCE SPECIFICATIONS

## Ramping Profile

**Note:** The multi-speed circulator blower also offers several custom ON/OFF ramping profiles. These profiles may be used to enhance cooling performance and increase comfort level. The ramping profiles are selected using DIP switches 5 and 6. Refer to the following figure for switch positions and their corresponding taps. Refer to the bullet points below for a description of each ramping profile. Verify CFM by noting the number displayed on the dual 7-segment LED display.

Switch Bank: S4		
Ramping Profiles	DIP Switch No.	
	5	6
A*	OFF	OFF
B	ON	OFF
C	OFF	ON
D	ON	ON
(*Indicates factory setting)		

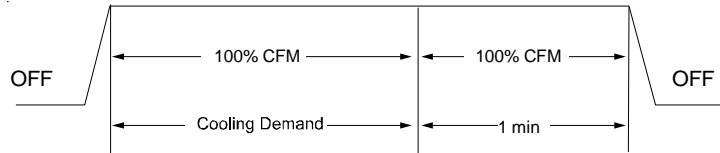

**Profile A:** provides only an OFF delay of one (1) minute at 100% of the cooling demand airflow.

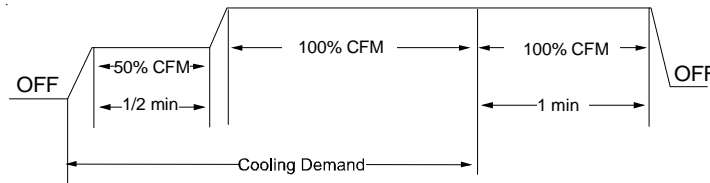

**Profile B:** ramps up to full cooling demand airflow by first stepping up to 50% of the full demand for 30 seconds. The motor then ramps to 100% of the required airflow. A one (1) minute OFF delay at 100% of the cooling airflow is provided.

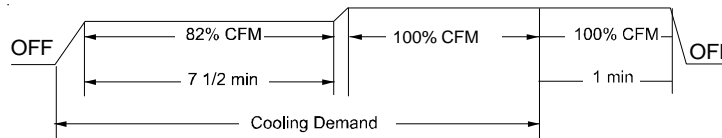

**Profile C:** ramps up to 82% of the full cooling demand airflow and operates there for approximately 7 1/2 minutes. The motor then steps up to the full demand airflow. Profile C also has a one (1) minute 100% OFF delay.

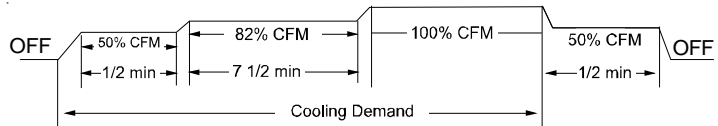

**Profile D:** ramps up to 50% of the demand for 1/2 minute, then ramps to 82% of the full cooling demand airflow and operates there for approximately 7 1/2 minutes. The motor then steps up to the full demand airflow. Profile D has a 1/2 minute at 50% airflow OFF delay.

1. Units are shipped without filter(s). CFM in chart is without filter(s).
2. All furnaces shipped with heating speed set at "B" and cooling speed set at "D". Installer should adjust blower speed as needed. The first task is to determine the proper airflow for the cooling system.
3. For most cooling applications, about 400 CFM per ton is desirable.
4. The chart is for information only. For satisfactory operation, external static pressure not to exceed value shown on rating plate.
5. Do not operate above 0.5" w.c. ESP in heating mode. Operating between 0.5" w.c. and 0.8" w.c. is tabulated for cooling purposes only.
6. \* Motor CFM minimum.



# PERFORMANCE

BTU OUTPUT vs TEMPERATURE RISE CHART

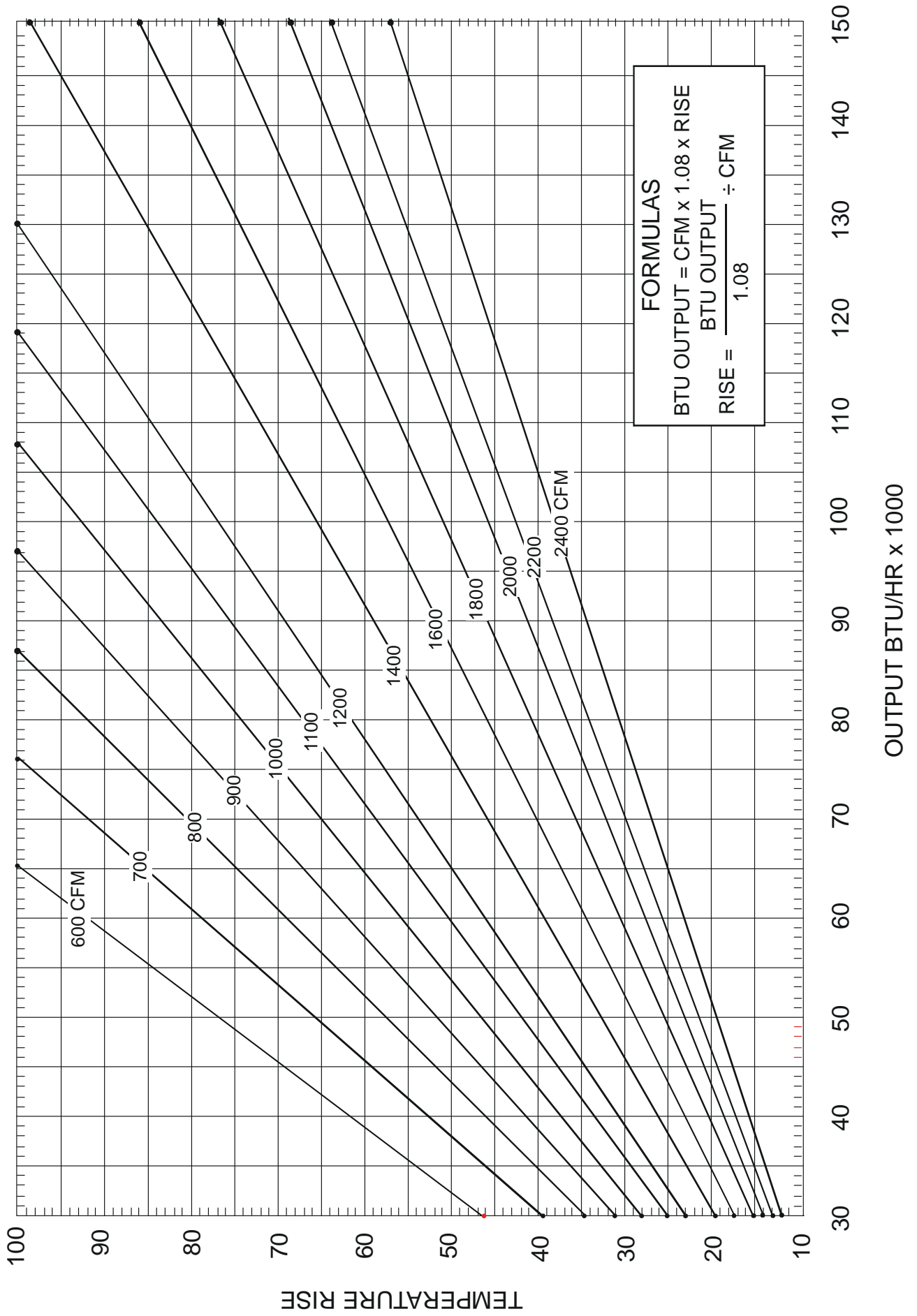

# WIRING DIAGRAMS

\*CVC9/\*MVC95\_AA



**WARNING**

**HIGH VOLTAGE!**  
DISCONNECT ALL POWER BEFORE SERVICING OR INSTALLING THIS UNIT. MULTIPLE POWER SOURCES MAY BE PRESENT. FAILURE TO DO SO MAY CAUSE PROPERTY DAMAGE, PERSONAL INJURY OR DEATH.

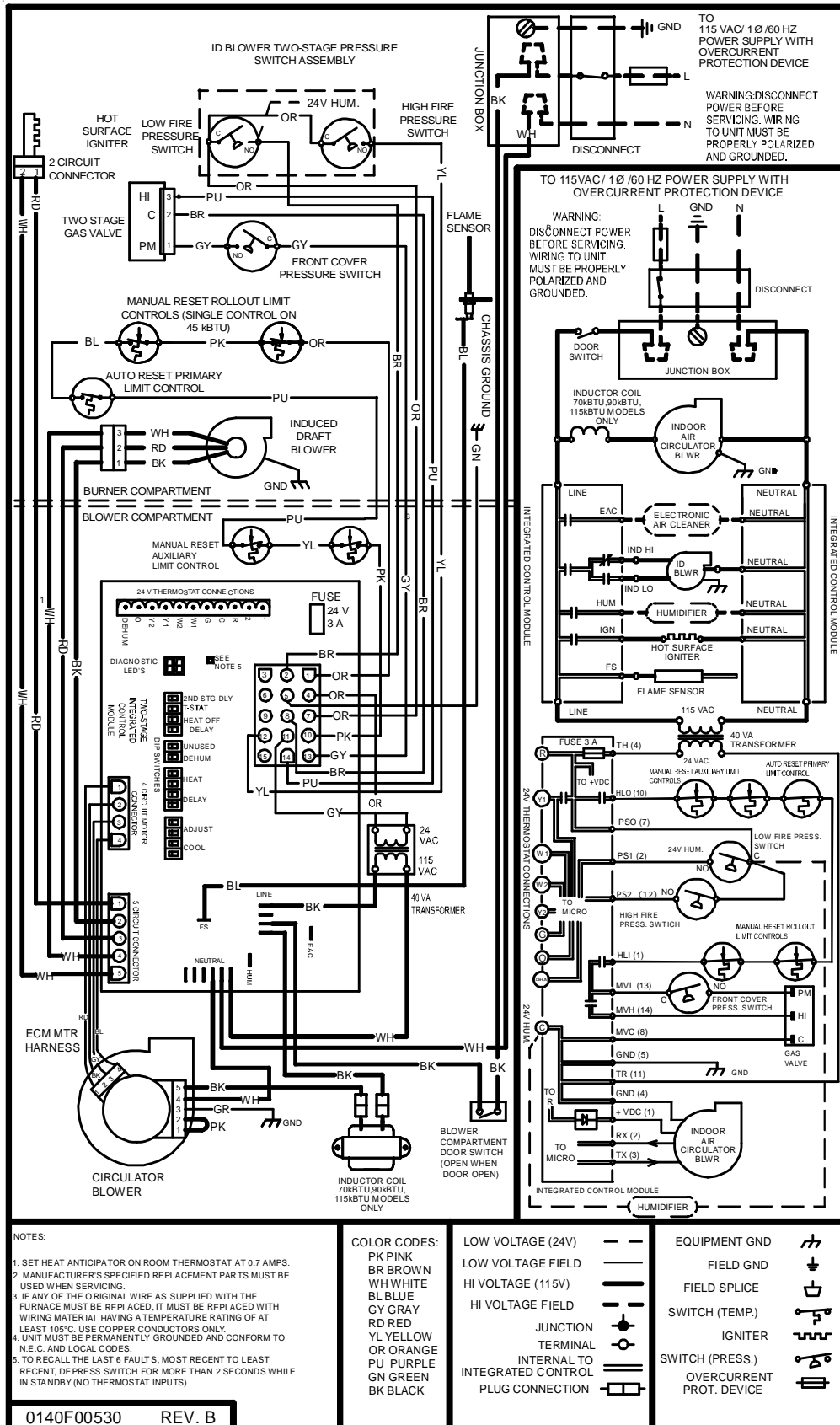

**NOTES:**

1. SET HEAT ANTICIPATOR ON ROOM THERMOSTAT AT 0.7 AMPS.
2. MANUFACTURER'S SPECIFIED REPLACEMENT PARTS MUST BE USED WHEN SERVICING.
3. IF ANY OF THE ORIGINAL WIRE AS SUPPLIED WITH THE FURNACE MUST BE REPLACED, IT MUST BE REPLACED WITH WIRING MATERIAL HAVING A TEMPERATURE RATING OF AT LEAST 105°C. USE COPPER CONDUCTORS ONLY.
4. UNIT MUST BE PERMANENTLY GROUNDED AND CONFORM TO N.E.C. AND LOCAL CODES.
5. TO RECALL THE LAST 6 FAULTS, MOST RECENT TO LEAST RECENT, DEPRESS SWITCH FOR MORE THAN 2 SECONDS WHILE IN STANDBY (NO THERMOSTAT INPUTS)

**COLOR CODES:**  
PK PINK  
BR BROWN  
WH WHITE  
BL BLUE  
GY GRAY  
RD RED  
YL YELLOW  
OR ORANGE  
PU PURPLE  
GN GREEN  
BK BLACK

**LOW VOLTAGE (24V)** ---  
**LOW VOLTAGE FIELD** ———  
**HI VOLTAGE (115V)** ———  
**HI VOLTAGE FIELD** ———

**JUNCTION** ●  
**TERMINAL** ○  
**INTERNAL TO INTEGRATED CONTROL** ———  
**PLUG CONNECTION** ———

**EQUIPMENT GND** ———  
**FIELD GND** ———  
**FIELD SPICE** ———  
**SWITCH (TEMP.)** ———  
**IGNITER** ———  
**SWITCH (PRESS.)** ———  
**OVERCURRENT PROT. DEVICE** ———

0140F00530 REV. B

Wiring is subject to change. Always refer to the wiring diagram on the unit for the most up-to-date wiring.

# WIRING DIAGRAMS

\*CVC9/\*MVC95\_AB

WARNING

**HIGH VOLTAGE!**  
**DISCONNECT ALL POWER BEFORE SERVICING OR INSTALLING THIS UNIT. MULTIPLE POWER SOURCES MAY BE PRESENT. FAILURE TO DO SO MAY CAUSE PROPERTY DAMAGE, PERSONAL INJURY OR DEATH.**

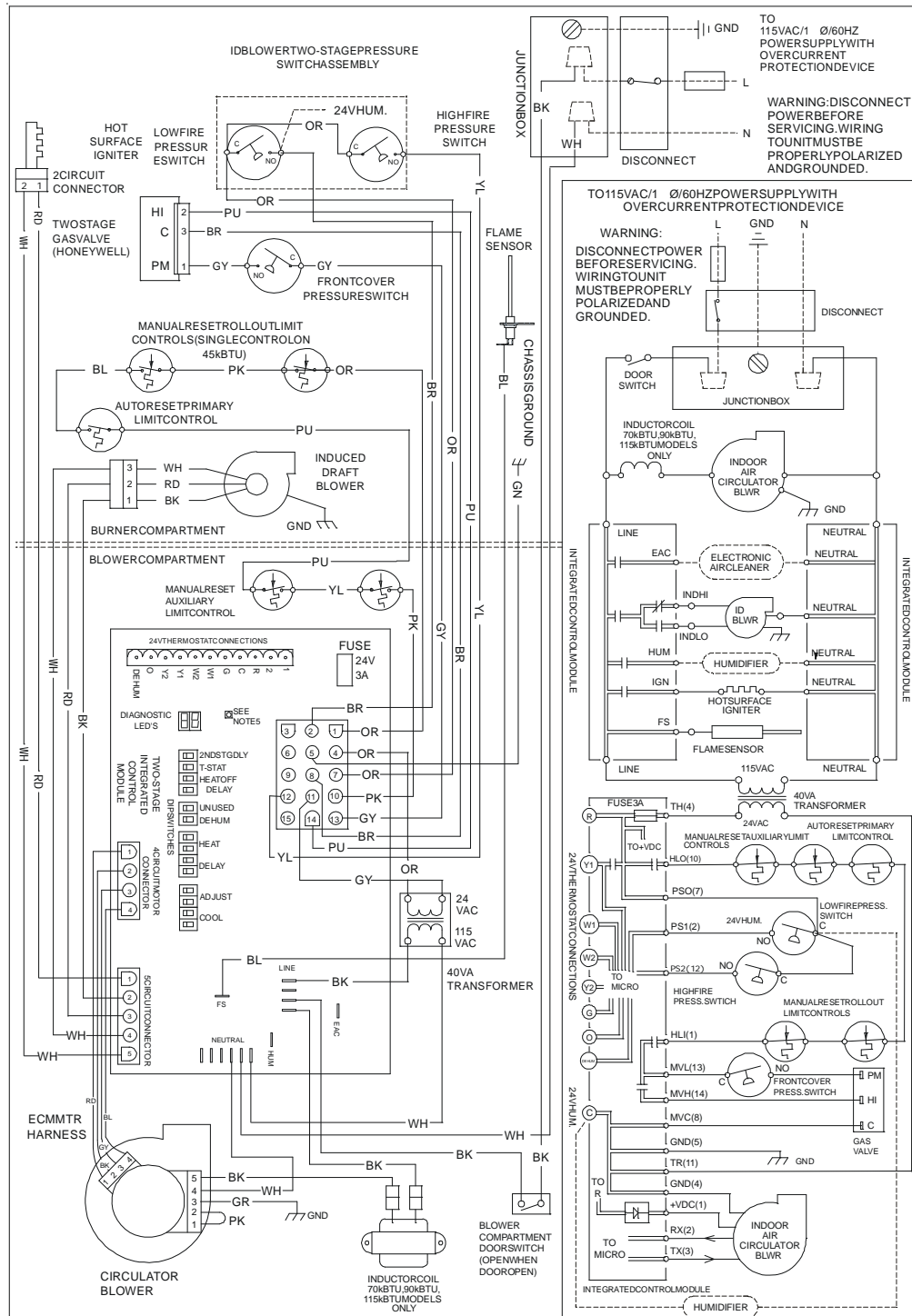

<p><b>NOTES:</b></p> <ol style="list-style-type: none"> <li>SET THE ANTICIPATOR ON ROOM THERMOSTAT TO 7 AMPS.</li> <li>MANUFACTURER'S SPECIFIED REPLACEMENT PARTS MUST BE USED WHEN SERVICING.</li> <li>IF ANY OF THE ORIGINAL WIRE IS SUPPLIED WITH THE FURNACE, IT MUST BE REPLACED WITH WIRING MATERIAL HAVING A TEMPERATURE RATING OF AT LEAST 105°C. USE COPPER CONDUCTOR ONLY.</li> <li>UNIT MUST BE PERMANENTLY GROUNDED AND CONFORM TO N.E.C. AND LOCAL CODES.</li> <li>TO RECALL THE LAST 5 FAULTS, MOST RECENT TO LEAST RECENT, DEPRESS SWITCH FOR MORE THAN 2 SECONDS WHILE INSTALLED BY (NOT THERMOSTAT INPUTS)</li> </ol>	<p><b>COLOR CODES:</b></p> <ul style="list-style-type: none"> <li>PK PINK</li> <li>BR BROWN</li> <li>WH WHITE</li> <li>BL BLUE</li> <li>GY GRAY</li> <li>RD RED</li> <li>YL YELLOW</li> <li>OR ORANGE</li> <li>PU PURPLE</li> <li>NG GREEN</li> <li>BK BLACK</li> </ul>	<table style="width: 100%; border-collapse: collapse;"> <tr> <td style="border-right: 1px dashed black; padding-right: 5px;">LOW VOLTAGE (24V)</td> <td style="text-align: center;">---</td> <td style="padding-left: 5px;">EQUIPMENT GND</td> <td style="text-align: center;"></td> </tr> <tr> <td style="border-right: 1px solid black; padding-right: 5px;">LOW VOLTAGE FIELD</td> <td style="text-align: center;">---</td> <td style="padding-left: 5px;">FIELD GND</td> <td style="text-align: center;"></td> </tr> <tr> <td style="border-right: 1px solid black; padding-right: 5px;">HIGH VOLTAGE (115V)</td> <td style="text-align: center;">---</td> <td style="padding-left: 5px;">FIELD SPLICE</td> <td style="text-align: center;"></td> </tr> <tr> <td style="border-right: 1px dashed black; padding-right: 5px;">HIGH VOLTAGE FIELD</td> <td style="text-align: center;">---</td> <td style="padding-left: 5px;">SWITCH (TEMP.)</td> <td style="text-align: center;"></td> </tr> <tr> <td style="border-right: 1px solid black; padding-right: 5px;">JUNCTION</td> <td style="text-align: center;"></td> <td style="padding-left: 5px;">IGNITER</td> <td style="text-align: center;"></td> </tr> <tr> <td style="border-right: 1px solid black; padding-right: 5px;">INTERNAL TERMINAL</td> <td style="text-align: center;"></td> <td style="padding-left: 5px;">SWITCH (PRESS.)</td> <td style="text-align: center;"></td> </tr> <tr> <td style="border-right: 1px solid black; padding-right: 5px;">INTEGRATED CONTROL</td> <td style="text-align: center;"></td> <td style="padding-left: 5px;">OVERCURRENT PROT. DEVICE</td> <td style="text-align: center;"></td> </tr> <tr> <td style="border-right: 1px solid black; padding-right: 5px;">PLUG CONNECTION</td> <td style="text-align: center;"></td> <td></td> <td></td> </tr> </table>	LOW VOLTAGE (24V)	---	EQUIPMENT GND		LOW VOLTAGE FIELD	---	FIELD GND		HIGH VOLTAGE (115V)	---	FIELD SPLICE		HIGH VOLTAGE FIELD	---	SWITCH (TEMP.)		JUNCTION		IGNITER		INTERNAL TERMINAL		SWITCH (PRESS.)		INTEGRATED CONTROL		OVERCURRENT PROT. DEVICE		PLUG CONNECTION			
LOW VOLTAGE (24V)	---	EQUIPMENT GND																																
LOW VOLTAGE FIELD	---	FIELD GND																																
HIGH VOLTAGE (115V)	---	FIELD SPLICE																																
HIGH VOLTAGE FIELD	---	SWITCH (TEMP.)																																
JUNCTION		IGNITER																																
INTERNAL TERMINAL		SWITCH (PRESS.)																																
INTEGRATED CONTROL		OVERCURRENT PROT. DEVICE																																
PLUG CONNECTION																																		
<p>0140F00661 REV.B</p>																																		

Wiring is subject to change. Always refer to the wiring diagram on the unit for the most up-to-date wiring.

# SCHEMATICS

**WARNING**

**HIGH VOLTAGE!**  
 DISCONNECT ALL POWER BEFORE SERVICING OR INSTALLING THIS UNIT. MULTIPLE POWER SOURCES MAY BE PRESENT. FAILURE TO DO SO MAY CAUSE PROPERTY DAMAGE, PERSONAL INJURY OR DEATH.

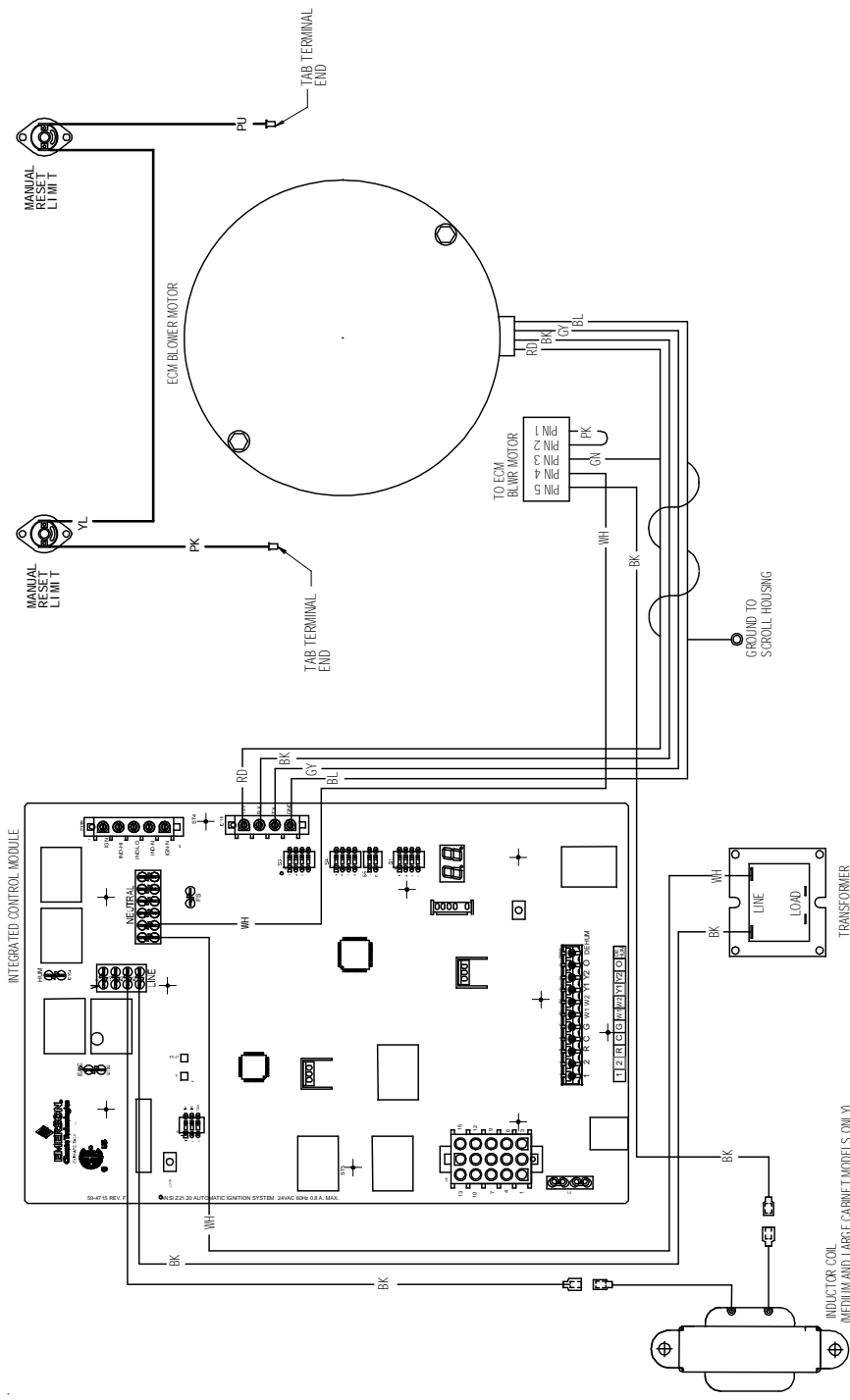

**BLOWER ASSEMBLY SCHEMATIC**  
 ACVC9/AMVC95/GVCV9/GMVC95\_\_\_\_X\* MODEL FURNACES  
 This schematic is for reference only. Not all wiring is as shown above,  
 refer to the appropriate wiring diagram for the unit being serviced.

Wiring is subject to change. Always refer to the wiring diagram on the unit for the most up-to-date wiring.

# SCHEMATICS

**WARNING**

**HIGH VOLTAGE!**  
**DISCONNECT ALL POWER BEFORE SERVICING OR INSTALLING THIS UNIT. MULTIPLE POWER SOURCES MAY BE PRESENT. FAILURE TO DO SO MAY CAUSE PROPERTY DAMAGE, PERSONAL INJURY OR DEATH.**



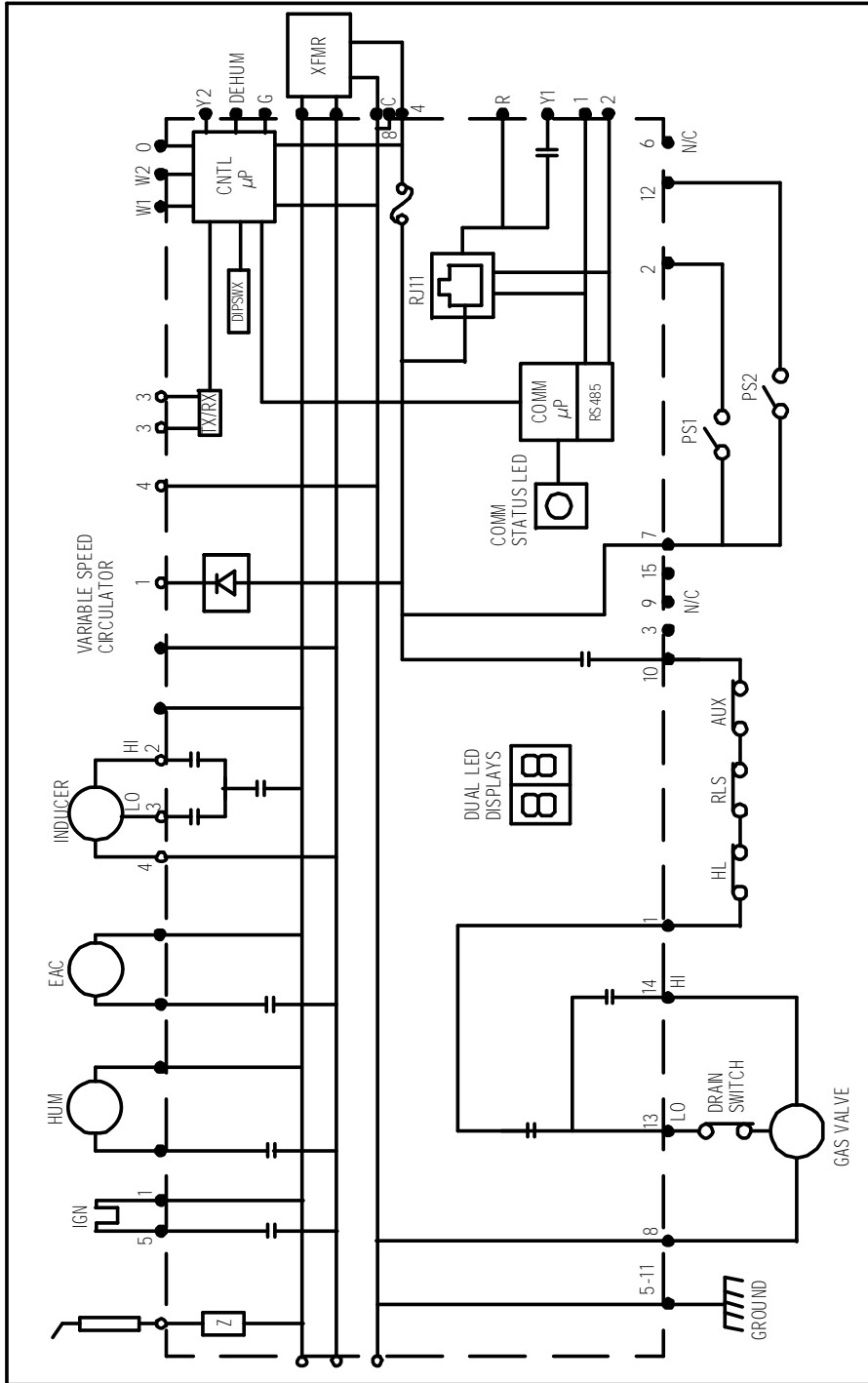

WIRING SCHEMATIC

TYPICAL SCHEMATIC  
 ACVC9/AMV95/GCVC9/GMVC95\_X\* MODEL FURNACES  
 WR 50C51-289 INTEGRATED IGNITION CONTROL

This schematic is for reference only. Not all wiring is as shown above. Refer to the appropriate wiring diagram for the unit being serviced.

Wiring is subject to change. Always refer to the wiring diagram on the unit for the most up-to-date wiring.